

Viscoelastic or Viscoplastic Glucose Theory (VGT #47): Using Viscoplasticity/Viscoplasticity to Explore the Inter-Relationships on Cancer risk % Versus Sensor Measured Fasting Plasma Glucose and Body Weight Based on Eleven Collected Annual Data over a 10+ Year Period From 1/1/2012 to 3/20/2022 using the GH-Method: Math-Physical Medicine (No. 632)

Gerald C Hsu

EclaireMD Foundation, USA

***Corresponding author**

Gerald C Hsu, EclaireMD Foundation, USA

Submitted: 15 Jun 2022; **Accepted:** 20 Jun 2022; **Published:** 07 Jul 2022

Citation: Gerald C Hsu .(2022). *Viscoelastic or Viscoplastic Glucose Theory (VGT #47): Using Viscoplasticity/Viscoplasticity to Explore the Inter-Relationships on Cancer risk % Versus Sensor Measured Fasting Plasma Glucose and Body Weight Based on Eleven Collected Annual Data over a 10+ Year Period From 1/1/2012 to 3/20/2022 using the GH-Method: Math-Physical Medicine (No. 632)*. *J App Mat Sci & Engg Res*, 6(2), 01-11.

Abstract

The purpose of this research article is to explore a possible link between cancer risk probability percentage (Cancer %) and body weight (BW) in the early morning. Body weight is very easy to measure by standing on a weight scale. Weight in the early morning is highly correlated with fasting plasma glucose (FPG) measured in the early morning or averaged glucose during sleeping hours. FPG also serves as the baseline of postprandial plasma glucose (PPG) and contributes around 25% to 29% of daily average glucose (eAG). Daily average glucose levels or quarterly HbA1C values (average eAG during the past 90-115 days) determine the severity of diabetes disease. Finally, diabetes is one of the major influential chronic diseases for developing many kinds of diseases and complications, including cancers. From the author's mathematical view, in this biomedical field, an output biomarker sometimes turns into an input biomarker of a third biomarker. Therefore, many biomedical problems can be described as a scenario of the matrix with "m by n by p" dimensions.

Since 2012, the author has been collecting his body weight (BW) and finger-piercing glucose values each day. In addition, he accumulates medical conditions data including blood pressure (BP), heart rate (HR), and blood lipids along with lifestyle details (LD). Based on his collected big data, he further organized them into two main groups. The first is the medical conditions group (MC) with 4 categories: weight, glucose, BP, and blood lipids. The second is the LD group with 6 categories: food & diet, exercise, water intake, sleep, stress, and daily routines. At first, he collected his data on a daily basis since Y2012 and then calculated a unique combined daily score for each of the 10 categories within the MC and LD groups. The combined scores of the 2 groups, 10 categories, and 500+ detailed elements constitute an overall "metabolism index (MI) model". This MI model includes the root causes from 6 major lifestyle inputs and symptoms from 4 rudimentary chronic diseases: obesity, diabetes, hypertension, and hyperlipidemia. Therefore, it can serve as the foundation and building block for his additional research work that can expand into various diseases associated with different organs, such as cancers.

As we know, lifestyle details cause rudimentary chronic diseases which further influence more complicated diseases, such as heart problems (CVD & CHD), chronic kidney disease (CKD), stroke, diabetic retinopathy (DR), neuropathy, hypothyroidism, diabetic constipation, diabetic skin fungal infection, and others including cancers. Some genetic conditions and lifetime unhealthy habits, such as smoking, alcohol consumption, and illicit drug use would account for approximately 15% to 25% of the root cause of chronic diseases & their complications, including cancers and dementia. Some external factors - environmental factors and viral infections, such as radiation, air and water pollution, food poison and pollution, toxic chemicals, and hormonal therapy can also contribute to the causes of a variety of cancers.

All of the above-mentioned diseases fall into the category of "symptoms" which are the "root causes" of poor living environments and unhealthy lifestyles.

Of course, his calculated risk probability % for CVD, Strokes, and various cancers have differences in their root-cause variables, their associated weighting factors, and certain biomedical assumptions. Specifically, the CVD/

Stroke risk includes two major scenarios that combine emphasized weights i.e., **blood vessel blockage due to blood glucose and blood lipids, while blood vessel rupture caused by blood glucose and BP. However, the cancer risk also consists of additional influential factors from environmental conditions and viral infections**, on top of genetic conditions, 3 lifetime bad habits, 4 chronic medical conditions, and 6 lifestyle details that are identical to the CVD risk. Since December 2021, the author has applied theories of viscoelasticity and viscoplasticity (VGT) from physics and engineering disciplines to investigate more than 45 sets of input/output biomarkers. His purpose is to identify certain hidden relationships between output biomarkers, e.g. CVD risk or Cancer risk, and their corresponding input biomarkers, such as fasting plasma glucose (FPG) and BW measured either during sleeping hours or in the early morning.

The hidden biophysical behaviors and possible inter-relationships among these three biomarkers, cancer risk vs. FPG/BW, are “time-dependent” and change from time to time. **This important time-dependency characteristic provides insight into the CVD or Cancer risk’s moving pattern. It covers curve shape, the associated energy created or stored inside during the process of stress up-loading (moving upward or increasing) and stress down-loading (moving downward or decreasing) of the input biomarkers of FPG or BW along with the output biomarker of CVD or Cancer risk %.**

Sometimes, the author also conducts his biomedical analyses for the same set of selected biomarkers using the **statistical regression method** similar to many other traditional medical researchers. However, generally speaking, statistical methods only deal with numerical characteristics of collected datasets and do not connect with the internal physical characteristics or behaviors of biomarkers in internal organs. In other words, the statistical method has no implicit connection with external biophysical behavior or internal biomedical properties. The reality is that **the accuracy and applicability of the results using any statistical method are heavily dependent on the internal characteristics of the selected data sample - not just the size of the selected dataset or the time-window coverage of the chosen data.** Therefore, we must be careful in selecting an appropriate statistical method and a suitable time window of data. Of course, we must also interpret the analysis results using statistical tools cautiously. Nevertheless, he has learned that, **for many cases but not all cases**, a correlation analysis between two biomarkers is extremely useful to serve as a **pre-examination tool** before pursuing a further investigation.

In this analysis, he performed basic correlation coefficient analyses of the dataset with three biomarkers, Cancer risk %, finger-piercing FPG (F. FPG), and BW, by **choosing a time window of 10+ years, with 11 annual data.** The following displays his pre-examination analysis using statistical correlations:
Three sets of Correlations using 8 semi-annual data (1/1/2012 - 3/20/2022):

Cancer vs. F.FPG = 90%;
Cancer vs. BW = 96%,
F.FPG vs. BW = 94%

This proves that the 10+ year time window with 11 annual datasets (not necessarily more data elements) is good enough to provide sufficient insight to pursue his follow-up VGT analysis.

The following defined equations are used to establish the stress-strain diagram in a space domain (SD):

strain = ϵ (Cancer risk %)
= individual Cancer risk % at the present time

Stress

= σ (based on the change rate of strain, Cancer risk, multiplying with a viscosity factor, F.FPG or BW)
= $\eta * (d\epsilon/dt)$
= $\eta * (d\text{-strain}/d\text{-time})$
= (viscosity factor η using individual normalized F.FPG or normalized BW at present time) * (Cancer risk at present time - Cancer risk at a previous time)

Next, he applies the viscoelastic perturbation model to calculate the following predicted CVD risk %.

Predicted Cancer risk %
= strain value (Cancer risk %) at present time + stress value at present time (i.e., Cancer risk change rate * normalized F.FPG or normalized BW as viscosity factor)

In the comparison of the perturbation model and viscoelastic perturbation model, they identify the use of the change rate for Biomarker A but multiplied with different factors, either a perturbation factor or a viscosity factor. These two factors serve as an “amplification factor” on the Biomarker A’s behavior. Here, it can be expressed mathematically as:

$A = A_0 + \epsilon A_1$
= A_0 (initial value) + (ϵ = amplification factor, either perturbation factor or viscosity factor) * (A_1 = change rate of A)

In both of the perturbation model and viscoelastic perturbation model, they use the change rate for Biomarker A multiplying with a factors, either a perturbation factor or a viscosity factor. These two factors serve as an “amplification creator” on the Biomarker A’s behavior. Here, it can be expressed mathematically as:

$$A = A_0 + \varepsilon A_1$$

= A_0 (initial value) + (ε = amplification factor, either perturbation factor or viscosity factor) * (A_1 = first order of A’s change rate)

However, the measurement units for glucose and weight were defined a long time ago by scientists without considering their biomedical means in terms of their inter-relationship. Therefore, to place them on even ground with sufficient biomedical sense, the author has decided to normalize these two biomarkers to serve as viscosity factors using the following two formulas:

$$\text{Normalized S.FPG} = \text{S.FPG} / 120$$

$$\text{Normalized BW} = \text{BW} / 170$$

Where 120 mg/dL is considered the dividing line between normal condition and diabetes condition. For his height of 5’9.5” (176.5 cm), at 170 lbs. (77.3 kg) of BW would provide a normal BMI level of 25.0.

To offer a simple explanation to readers who do not have a physics or engineering background, the author includes a brief excerpt from Wikipedia regarding the description of basic concepts for elasticity and plasticity theories, viscoelasticity and viscoplasticity theories, perturbation theory from the disciplines of engineering and physics in the Method section.

In summary, the following four described steps show the sequential chain reactions of causes and symptoms in this case study:

- (1) An unhealthy diet and food portion overconsumption with a sedentary lifestyle would cause overweight or obese conditions.
- (2) Most likely, an overweight or obese person would have higher fasting glucose in the early morning (86% of correlation between BW and FPG based on his data from 10/1/2013 to 3/22/2022).
- (3) FPG serves as an indicator of the health state of the pancreatic beta cells (insulin quality and quantity) as well as the baseline of PPG; therefore, a hyper-FPG person most likely would have hyperglycemic conditions (high eAG and high HbA1C).
- (4) Being overweight or having obesity increases the risk of getting cancer. Studies have shown that obesity or overweight is linked with a higher risk of getting 13 types of cancer. These cancers make up 40% of all cancers diagnosed in the United States each year. Many things are associated with cancer, but avoiding tobacco use and keeping a healthy weight are two of the most important steps you can take to lower your risk of getting cancer. 55 percent of all cancers diagnosed in women and 24 percent of those diagnosed in men are associated with being overweight and obese. A large body of literature indicates that as much as 30% of all cancer cases are linked to poor dietary habits, and are therefore preventable. The proportion reaches 70% for cancers of the gastrointestinal tract. Maintaining a healthy weight throughout life may be one of the most important ways to protect against cancer (US-CDC, June 11, 2007).

There are five observed conclusions from this research work:

- (1) From the analysis results of both time-domain (biomarker versus time) and space-domain (stress-strain diagrams), his Cancer risk % (strain) is moving from a high 57% in Y2012 to a lower 40% in Y2022. Both curves have shown viscoplastic behavior (with a big opening of the hysteresis loop).
- (2) The stress component (equals to Cancer risk change rate * F.FPG or BW) has two dominating influential components. First, the Cancer change rate indicates the Cancer risk curve fluctuation which determines the curve shape and its moving direction. Besides, his earlier research results and other papers have already demonstrated the importance of glucose fluctuation or glycemic variability (GF or GV) in diabetes control. Second, the viscosity factor (either F.FPG or BW) offers an “amplification or shrinkage” effect on the stress-strain curve which then determines the “magnitude” of the stress-strain curve. That is why he utilizes the normalized F.FPG value and the normalized BW value as his chosen viscosity factors.
- (3) These 2 normalized biomarkers, FPG/120 or BW/170, cause the numerical values of the viscosity factors to fall in a very narrow range between 0.x (healthy) to 1.x (unhealthy). This would dampen the original wide range of biomarker data for glucose and weight into a narrow range but still preserve their inherited biomedical characteristics.
- (4) **The areas of two hysteresis loops are 48.21 for the stress-strain curve using F.FPG and 48.03 for the stress-strain curve using BW (almost identical to each other).** This fact offers proof of the VGT predicted CVD risk can use either normalized F.FPG or normalized BW as its viscosity factor which has no area difference (two energy levels are identical to each other). The same conclusion can also be observed from the visco-perturbed CVD versus the MI calculated CVD in time-domain with 95% correlations and 96% - 97% prediction accuracies.
- (5) As a reference, he conducted one additional VGT analysis using F.FPG as the symptom and BW as its cause. This analysis result demonstrated that not only fasting glucose and BW are the causes for Cancer risk, but BW also served as the cause of diabetes conditions (high glucose, particularly high fasting glucose). This example illustrates what he talked about earlier of “m by n by p” matrix.

Obesity, diabetes, and cancers do not occur suddenly, and are usually the result of a patient's unhealthy lifestyle, environmental exposure, or viral infection over a long period of time. About 24% of male cancer patients and 55% of female cancer patients are diagnosed with diabetes as well. Therefore, for patients with both cancers and diabetes, in order to lower their risks of having cancers, a longer period of continuous efforts on controlling their body weight and lowering their HbA1C is helpful and necessary.

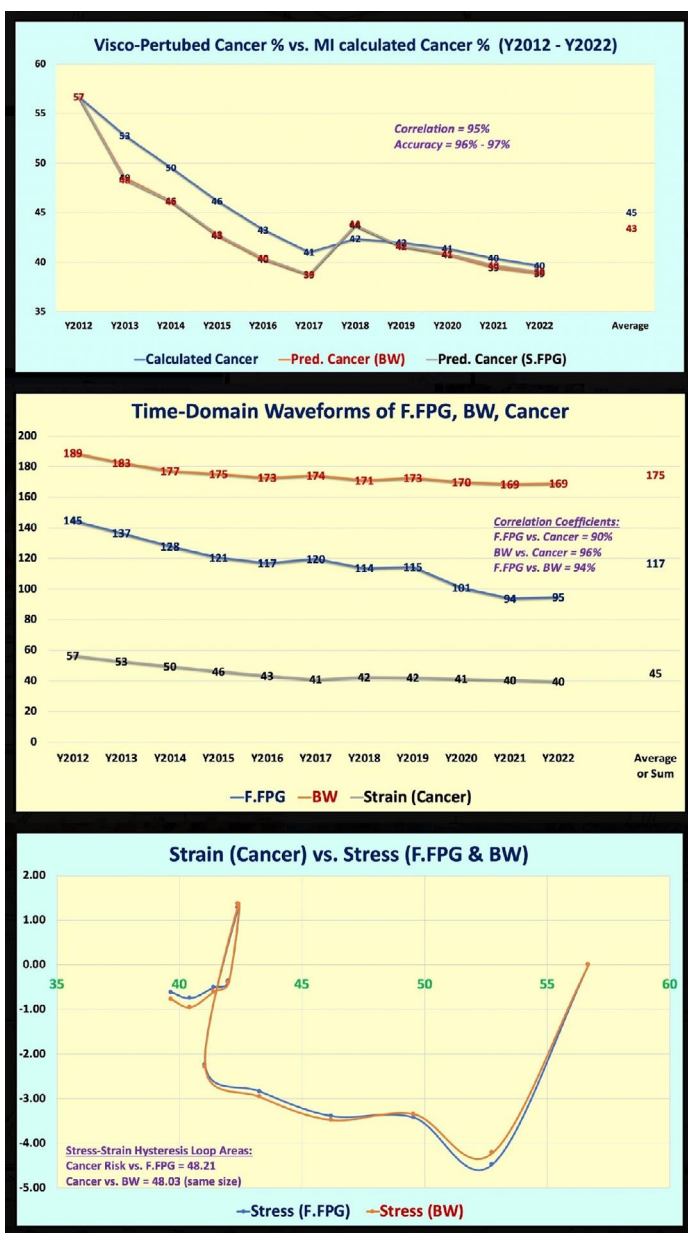

From the author's mathematical view, in this biomedical field, an output biomarker sometimes turns into an input biomarker of a third biomarker. Therefore, many biomedical problems can be described as a scenario of the matrix with "m by n by p" dimensions.

Since 2012, the author has been collecting his body weight (BW) and finger-piercing glucose values each day. In addition, he accumulates medical conditions data including blood pressure (BP), heart rate (HR), and blood lipids along with lifestyle details (LD). Based on his collected big data, he further organized them into two main groups. The first is the medical conditions group (MC) with 4 categories: weight, glucose, BP, and blood lipids. The second is the LD group with 6 categories: food & diet, exercise, water intake, sleep, stress, and daily routines. At first, he collected his data on a daily basis since Y2012 and then calculated a unique combined daily score for each of the 10 categories within the MC and LD groups. The combined scores of the 2 groups, 10 categories, and 500+ detailed elements constitute an overall "metabolism index (MI) model". This MI model includes the root causes from 6 major lifestyle inputs and symptoms from 4 rudimentary chronic diseases: obesity, diabetes, hypertension, and hyperlipidemia. Therefore, it can serve as the foundation and building block for his additional research work that can expand into various diseases associated with different organs, such as cancers.

As we know, lifestyle details cause rudimentary chronic diseases which further influence more complicated diseases, such as heart problems (CVD & CHD), chronic kidney disease (CKD), stroke, diabetic retinopathy (DR), neuropathy, hypothyroidism, diabetic constipation, diabetic skin fungal infection, and others including cancers. Some genetic conditions and lifetime unhealthy habits, such as smoking, alcohol consumption, and illicit drug use would account for approximately 15% to 25% of the root cause of chronic diseases & their complications, including cancers and dementia. Some external factors - environmental factors and viral infections, such as radiation, air and water pollution, food poison and pollution, toxic chemicals, and hormonal therapy can also contribute to the causes of a variety of cancers.

Introduction

The purpose of this research article is to explore a possible link between cancer risk probability percentage (Cancer %) and body weight (BW) in the early morning. Body weight is very easy to measure by standing on a weight scale. Weight in the early morning is highly correlated with fasting plasma glucose (FPG) measured in the early morning or averaged glucose during sleeping hours. FPG also serves as the baseline of postprandial plasma glucose (PPG) and contributes around 25% to 29% of daily average glucose (eAG). Daily average glucose levels or quarterly HbA1C values (averaged eAG during the past 90-115 days) determine the severity of diabetes disease. Finally, diabetes is one of the major influential chronic diseases for developing many kinds of diseases and complications, including cancers.

All of the above-mentioned diseases fall into the category of "symptoms" which are the "root causes" of poor living environments and unhealthy lifestyles.

Of course, in his calculated risk probability % for CVD, Strokes, and various cancers have differences in their root-cause variables, their associated weighting factors, and certain biomedical assumptions. *Specifically, the CVD/Stroke risk includes two major scenarios that combine emphasized weights i.e., blood vessel blockage due to blood glucose and blood lipids, while blood vessel rupture caused by blood glucose and BP. However, the cancer risk also consists of additional influential factors from environmental conditions and viral infections, on top of genet-*

ic conditions, 3 lifetime bad habits, 4 chronic medical conditions, and 6 lifestyle details that are identical to the CVD risk.

Since December 2021, the author has applied theories of viscoelasticity and viscoplasticity (VGT) from physics and engineering disciplines to investigate more than 45 sets of input/output biomarkers. His purpose is to identify certain hidden relationships between output biomarkers, e.g. CVD risk or Cancer risk, and their corresponding input biomarkers, such as fasting plasma glucose (FPG) and BW measured either during sleeping hours or in the early morning.

The hidden biophysical behaviors and possible inter-relationships among these three biomarkers, cancer risk vs. FPG/BW, are "time-dependent" and change from time to time. This important time-dependency characteristic provides insight on the CVD or Cancer risk's moving pattern. It covers curve shape, the associated energy created or stored inside during the process of stress up-loading (moving upward or increasing) and stress down-loading (moving downward or decreasing) of the input biomarkers of FPG or BW along with the output biomarker of CVD or Cancer risk %.

Sometimes, the author also conducts his biomedical analyses for the same set of selected biomarkers using the **statistical regression method** similar to many other traditional medical researchers. However, generally speaking, statistical methods only deal with numerical characteristics of collected datasets and do not connect with the internal physical characteristics or behaviors of biomarkers in internal organs. In other words, the statistical method has no implicit connection with external biophysical behavior or internal biomedical properties. The reality is that **the accuracy and applicability of the results using any statistical method are heavily dependent on the internal characteristics of the selected data sample - not just the size of the selected dataset or the time-window coverage of the chosen data.** Therefore, we must be careful in selecting an appropriate statistical method and a suitable time window of data. Of course, we must also interpret the analysis results using statistic tools cautiously. Nevertheless, he has learned that, **for many cases but not all cases, a correlation analysis between two biomarkers is extremely useful to serve as a pre-examination tool before pursuing further investigation.**

In this analysis, he performed basic correlation coefficient analyses of the dataset with three biomarkers, Cancer risk %, finger-piercing FPG (F. FPG), and BW, by **choosing a time-window of 10+ years, with 11 annual data.** The following displays his pre-examination analysis using statistical correlations:

Three sets of Correlations using 8 semi-annual data (1/1/2012 - 3/20/2022):

Cancer vs. F.FPG = 90%;
Cancer vs. BW = 96%,
F.FPG vs. BW = 94%

This proves that the 10+ year time window with 11 annual datasets (not necessarily more data elements) is good enough to pro-

vide sufficient insight to pursue his follow-up VGT analysis.

The following defined equations are used to establish the stress-strain diagram in a space-domain (SD):

strain = ε (Cancer risk %)
= **individual Cancer risk % at present time**

Stress
= σ (based on change rate of strain, Cancer risk, multiplying with a viscosity factor, F.FPG or BW)
= $\eta * (d\varepsilon/dt)$
= $\eta * (d\text{-strain}/d\text{-time})$
= (viscosity factor η using individual normalized F.FPG or normalized BW at present time) * (Cancer risk at present time - Cancer risk at previous time)

Next, he applies the viscoelastic perturbation model to calculate the following predicted CVD risk %.

Predicted Cancer risk %
= strain value (Cancer risk %) at present time + stress value at present time (i.e., Cancer risk change rate * normalized F.FPG or normalized BW as viscosity factor)

In the comparison of the perturbation model and viscoelastic perturbation model, they identify the use of the change rate for Biomarker A but multiplied with different factors, either a perturbation factor or a viscosity factor. These two factors serve as an "amplification factor" on the Biomarker A's behavior. Here, it can be expressed mathematically as:

$A = A0 + \varepsilon A1$
= $A0$ (initial value) + (ε = amplification factor, either perturbation factor or viscosity factor) * ($A1$ = change rate of A)

In both the perturbation model and viscoelastic perturbation model, they use the change rate for Biomarker A multiplying with factors, either a perturbation factor or a viscosity factor. These two factors serve as an "amplification creator" on the Biomarker A's behavior. Here, it can be expressed mathematically as:

$A = A0 + \varepsilon A1$
= $A0$ (initial value) + (ε = amplification factor, either perturbation factor or viscosity factor) * ($A1$ = first order of A's change rate)

However, the measurement units for glucose and weight were defined a long time ago by scientists without considering their biomedical means in terms of their inter-relationship. Therefore, to place them on even ground with sufficient biomedical sense, the author has decided to normalize these two biomarkers to serve as viscosity factors using the following two formulas:

Normalized S.FPG = S.FPG / 120
Normalized BW = BW / 170

Where 120 mg/dL is considered the dividing line between normal condition and diabetes condition. For his height of 5'9.5"

(176.5 cm), at 170 lbs. (77.3 kg) of BW would provide a normal BMI level of 25.0.

To offer a simple explanation to readers who do not have a physics or engineering background, the author includes a brief excerpt from Wikipedia regarding the description of basic concepts for elasticity and plasticity theories, viscoelasticity and viscoplasticity theories, perturbation theory from the disciplines of engineering and physics in the Method section.

Methods

Elasticity, Plasticity, Viscoelasticity and Viscoplasticity

The Difference Between Elastic Materials and Viscoelastic Materials

(from "Soborthans, innovating shock and vibration solutions")

What are Elastic Materials?

Elasticity is the tendency of solid materials to return to their original shape after forces are applied on them. When the forces are removed, the object will return to its initial shape and size if the material is elastic.

What are Viscous Materials?

Viscosity is a measure of a fluid's resistance to flow. A fluid with large viscosity resists motion. A fluid with low viscosity flows. For example, water flows more easily than syrup because it has a lower viscosity. High viscosity materials might include honey, syrups, or gels – generally, things that resist flow. Water is a low viscosity material, as it flows readily. Viscous materials are thick or sticky or adhesive. Since heating reduces viscosity, these materials don't flow easily. For example, warm syrup flows more easily than cold.

What is Viscoelastic?

Viscoelasticity is the property of materials that exhibit both viscous and elastic characteristics when undergoing deformation. Synthetic polymers, wood, and human tissue, as well as metals at high temperature, display significant viscoelastic effects. In some applications, even a small viscoelastic response can be significant.

Elastic Behavior Versus Viscoelastic Behavior

The difference between elastic materials and viscoelastic materials is that viscoelastic materials have a viscosity factor and the elastic ones don't. Because viscoelastic materials have the viscosity factor, they have a strain rate dependent on time. Purely elastic materials do not dissipate energy (heat) when a load is applied, then removed; however, a viscoelastic substance does.

The following brief introductions are excerpts from Wikipedia:

"Elasticity (Physics)

The physical property is when materials or objects return to their original shape after deformation

In physics and materials science, **elasticity** is the ability of a body to resist a distorting influence and to return to its original size and shape when that influence or force is removed. Solid objects will deform when adequate loads are applied to them; if the

material is elastic, the object will return to its initial shape and size after removal. This is in contrast to plasticity, in which the object fails to do so and instead remains in its deformed state.

The physical reasons for elastic behavior can be quite different for different materials. In metals, the atomic lattice changes size and shape when forces are applied (energy is added to the system). When forces are removed, the lattice goes back to the original lower energy state. For rubbers and other polymers, elasticity is caused by the stretching of polymer chains when forces are applied.

Hooke's law states that the force required to deform elastic objects should be directly proportional to the distance of deformation, regardless of how large that distance becomes. This is known as perfect elasticity, in which a given object will return to its original shape no matter how strongly it is deformed. This is an ideal concept only; most materials that possess elasticity in practice remain purely elastic only up to very small deformations, after which plastic (permanent) deformation occurs.

In engineering, the elasticity of a material is quantified by the elastic modulus such as Young's modulus, bulk modulus, or shear modulus which measure the amount of stress needed to achieve a unit of strain; a higher modulus indicates that the material is harder to deform. The material's elastic limit or yield strength is the maximum stress that can arise before the onset of plastic deformation.

Plasticity (Physics)

Deformation of a solid material undergoing non-reversible changes of shape in response to applied forces.

In physics and materials science, **plasticity**, also known as **plastic deformation**, is the ability of a solid material to undergo permanent deformation, a non-reversible change of shape in response to applied forces. For example, a solid piece of metal being bent or pounded into a new shape displays plasticity as permanent changes occur within the material itself. In engineering, the transition from elastic behavior to plastic behavior is known as yielding

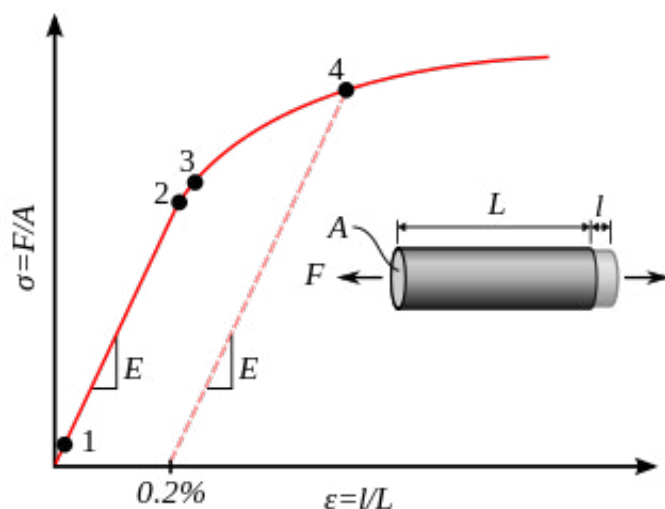

The stress-strain curve shows typical yield behavior for nonferrous alloys.

1. True elastic limit
2. Proportionality limit
3. Elastic limit
4. Offset yield strength

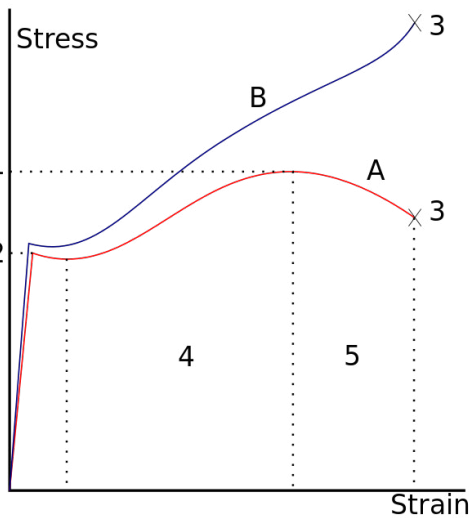

A stress-strain curve typical of structural steel.

- 1: Ultimate strength
- 2: Yield strength (yield point)
- 3: Rupture
- 4: Strain hardening region
- 5: Necking region
- A: Apparent stress (F/A_0)
- B: Actual stress (F/A)

Plastic deformation is observed in most materials, particularly metals, soils, rocks, concrete, and foams. However, the physical mechanisms that cause plastic deformation can vary widely. At a crystalline scale, plasticity in metals is usually a consequence of dislocations. Such defects are relatively rare in most crystalline materials, but are numerous in some and part of their crystal structure; in such cases, plastic crystallinity can result. In brittle materials such as rock, concrete and bone, plasticity is caused predominantly by slip at microcracks. In cellular materials such as liquid foams or biological tissues, plasticity is mainly a consequence of bubble or cell rearrangements, notably TI processes.

For many ductile metals, tensile loading applied to a sample will cause it to behave in an elastic manner. Each increment of the load is accompanied by a proportional increment in extension. When the load is removed, the piece returns to its original size. However, once the load exceeds a threshold – the yield strength – the extension increases more rapidly than in the elastic region; now when the load is removed, some degree of extension will remain.

Elastic deformation, however, is an approximation and its quality depends on the time frame considered and loading speed. If, as indicated in the graph opposite, the deformation includes elastic deformation, it is also often referred to as "elasto-plastic deformation" or "elastic-plastic deformation".

Perfect plasticity is a property of materials to undergo irreversible deformation without any increase in stresses or loads. Plastic materials that have been hardened by prior deformation, such as cold forming, may need increasingly higher stresses to deform further. Generally, plastic deformation is also dependent on the deformation speed, i.e. higher stresses usually have to be applied to increase the rate of deformation. Such materials are said to deform visco-plastically."

Viscoelasticity

Property of materials with both viscous and elastic characteristics under deformation.

In materials science and continuum mechanics, viscoelasticity is the property of materials that exhibit both viscous and elastic characteristics when undergoing deformation. Viscous materials, like water, resist shear flow and strain linearly with time when a stress is applied. Elastic materials strain when stretched and immediately return to their original state once the stress is removed.

Viscoelastic materials have elements of both of these properties and, as such, exhibit time-dependent strain. Whereas elasticity is usually the result of bond stretching along crystallographic planes in an ordered solid, viscosity is the result of the diffusion of atoms or molecules inside an amorphous material.

In the nineteenth century, physicists such as Maxwell, Boltzmann, and Kelvin researched and experimented with creep and recovery of glasses, metals, and rubbers. Viscoelasticity was further examined in the late twentieth century when synthetic polymers were engineered and used in a variety of applications. Viscoelasticity calculations depend heavily on the viscosity variable, η . The inverse of η is also known as fluidity, ϕ . The value of either can be derived as a function of temperature or as a given value (i.e. for a dashpot).

Depending on the change of strain rate versus stress inside a material, the viscosity can be categorized as having a linear, non-linear, or plastic response. When a material exhibits a linear response it is categorized as a Newtonian material. In this case, the stress is linearly proportional to the strain rate. If the material exhibits a non-linear response to the strain rate, it is categorized as Non-Newtonian fluid. There is also an interesting case where the viscosity decreases as the shear/strain rate remains constant. A material that exhibits this type of behavior is known as thixotropic. In addition, when the stress is independent of this strain rate, the material exhibits plastic deformation. Many viscoelastic materials exhibit rubber-like behavior explained by the thermodynamic theory of polymer elasticity. Cracking occurs when the strain is applied quickly and outside of the elastic limit. Ligaments and tendons are viscoelastic, so the extent of the potential damage to them depends both on the rate of the change of their length as well as on the force applied.

A viscoelastic material has the following properties:

- hysteresis is seen in the stress-strain curve
- stress relaxation occurs: step constant strain causes decreasing stress
- creep occurs: step constant stress causes increasing strain

• its stiffness depends on the strain rate or the stress rate.

Elastic Versus Viscoelastic Behavior

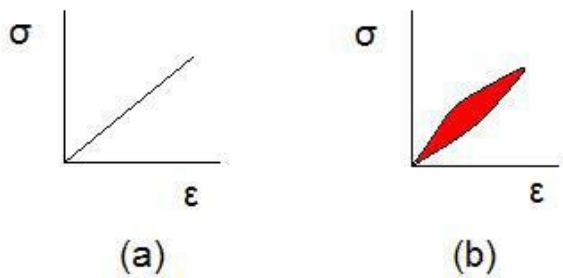

Stress–strain curves for a purely elastic material (a) and a viscoelastic material (b). The red area is a hysteresis loop and shows the amount of energy lost (as heat) in a loading and unloading cycle. It is equal to

$$\oint \sigma d\epsilon$$

where σ is stress and ϵ is strain.

Unlike purely elastic substances, a viscoelastic substance has an elastic component and a viscous component. **The viscosity of a viscoelastic substance gives the substance a strain rate dependence on time.** Purely elastic materials do not dissipate energy (heat) when a load is applied, then removed. However, a viscoelastic substance dissipates energy when a load is applied, then removed. **Hysteresis is observed in the stress-strain curve, with the area of the loop being equal to the energy lost during the loading cycle.** Since viscosity is the resistance to thermally activated plastic deformation, a viscous material will lose energy through a loading cycle. Plastic deformation results in lost energy, which is uncharacteristic of a purely elastic material's reaction to a loading cycle.

Specifically, viscoelasticity is a molecular rearrangement. When a stress is applied to a viscoelastic material such as a polymer, parts of the long polymer chain change positions. This movement or rearrangement is called “**creep**”. Polymers remain a solid material even when these parts of their chains are rearranging in order to accompany the stress, and as this occurs, it creates a back stress in the material. When the back stress is the same magnitude as the applied stress, the material no longer creeps. When the original stress is taken away, the accumulated back stresses will cause the polymer to return to its original form. **The material creeps, which gives the prefix visco-, and the material fully recovers, which gives the suffix -elasticity.**

Viscoplasticity

Viscoplasticity is a theory in continuum mechanics that describes the rate-dependent inelastic behavior of solids. Rate-dependence in this context means that the deformation of the material depends on the rate at which loads are applied. The inelastic behavior that is the subject of viscoplasticity is plastic deformation which means that the material undergoes unrecoverable deformations when a load level is reached. Rate-dependent plasticity is important for transient plasticity calculations. The main difference between rate-independent plastic and viscoplastic material models is that the latter exhibit not only permanent deformations after the application of loads but continue

to undergo a creep flow as a function of time under the influence of the applied load.

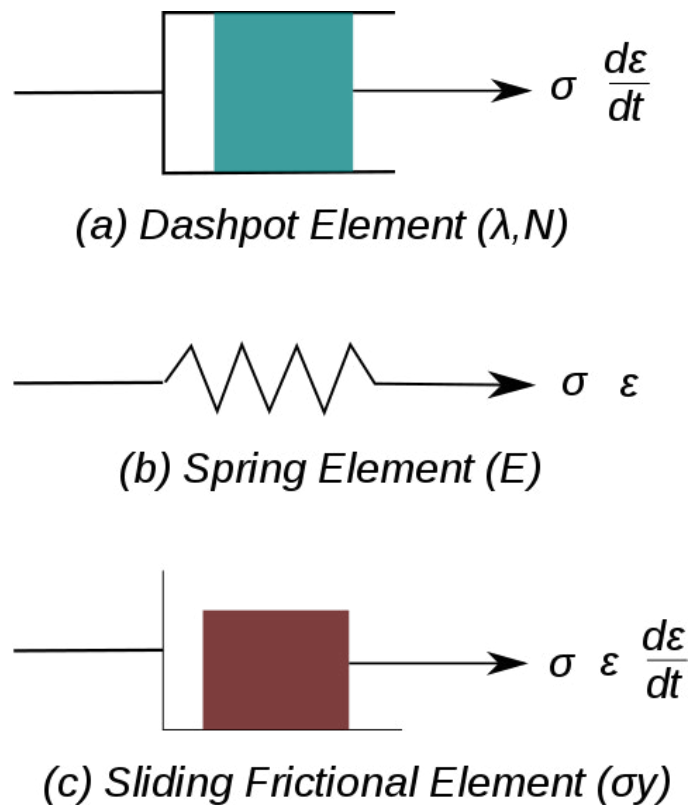

Figure 1: Elements used in one-dimensional models of viscoplastic materials.

The elastic response of viscoplastic materials can be represented in one dimension by Hookean spring elements. Rate-dependence can be represented by nonlinear dashpot elements in a manner similar to viscoelasticity. Plasticity can be accounted for by adding sliding frictional elements as shown in Figure 1. In Figure E is the modulus of elasticity, λ is the viscosity parameter and N is a power-law type parameter that represents non-linear dashpot [$\sigma(d\epsilon/dt) = \sigma = \lambda(d\epsilon/dt)^{1/N}$]. The sliding element can have a yield stress (σ_y) that is strain rate dependent, or even constant, as shown in Figure 1c.

Viscoplasticity is usually modeled in three dimensions using overstress models of the Perzyna or Duvaut-Lions types. In these models, the stress is allowed to increase beyond the rate-independent yield surface upon application of a load and then allowed to relax back to the yield surface over time. The yield surface is usually assumed not to be rate-dependent in such models. An alternative approach is to add a strain rate dependence to the yield stress and use the techniques of rate-independent plasticity to calculate the response of a material. For metals and alloys, viscoplasticity is the macroscopic behavior caused by a mechanism linked to the movement of dislocations in grains, with superposed effects of inter-crystalline gliding. The mechanism usually becomes dominant at temperatures greater than approximately one-third of the absolute melting temperature. However, certain alloys exhibit viscoplasticity at room temperature (300K). For polymers, wood, and bitumen, the theory of viscoplasticity is required to describe behavior beyond the limit of elasticity or viscoelasticity.

In general, viscoplasticity theories are useful in areas such as

- the calculation of permanent deformations,
- the prediction of the plastic collapse of structures,
- the investigation of stability,
- crash simulations,
- systems exposed to high temperatures such as turbines in engines, e.g. a power plant,
- dynamic problems and systems exposed to high strain rates.

Phenomenology

For qualitative analysis, several characteristic tests are performed to describe the phenomenology of viscoplastic materials. Some examples of these tests are

1. hardening tests at constant stress or strain rate,
2. creep tests at constant force, and
3. stress relaxation at constant elongation.

Strain Hardening Test

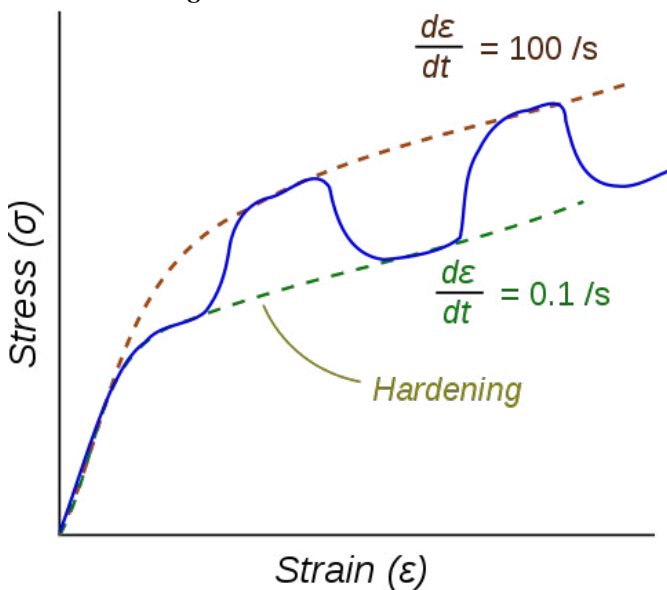

Figure 2: Stress-strain response of a viscoplastic material at different strain rates.

The dotted lines show the response if the strain rate is held constant. The blue line shows the response when the strain rate is changed suddenly.

One consequence of yielding is that as plastic deformation proceeds, an increase in stress is required to produce additional strain. This phenomenon is known as Strain/Work hardening. For a viscoplastic material, the hardening curves are not significantly different from those of rate-independent plastic material.

Nevertheless, three essential differences can be observed.

1. At the same strain, the higher the rate of strain the higher the stress
2. A change in the rate of strain during the test results in an immediate change in the stress-strain curve.
3. The concept of a plastic yield limit is no longer strictly applicable.

The hypothesis of partitioning the strains by decoupling the elastic and plastic parts is still applicable where the strains are

small, i.e.,

$$\epsilon = \epsilon_e + \epsilon_{vp}$$

where ϵ_e is the elastic strain and ϵ_{vp} is the viscoplastic strain.

To obtain the stress-strain behavior shown in blue in the figure, the material is initially loaded at a strain rate of 0.1/s. The strain rate is then instantaneously raised to 100/s and held constant at that value for some time. At the end of that time period the strain rate is dropped instantaneously back to 0.1/s and the cycle is continued for increasing values of strain. There is clearly a lag between the strain-rate change and the stress response. This lag is modeled quite accurately by overstress models (such as the Perzyna model) but not by models of rate-independent plasticity that have rate-dependent yield stress.”

Hysteresis and Avalanches

(from Professor James Sethna, physical science department of Cornell University)

Physicists in the US usually hear about hysteresis first in their sophomore or junior year. You likely won't hear about hysteresis again in your courses. It was an unpopular subject for decades. Experimentalists generally tried to get rid of it, so they could get publishable equilibrium, data. Theorists cringed from thinking about non-equilibrium, dirty materials with long-range elastic or magnetic forces. But styles change: dirt and non-equilibrium are now a major focus of research in physics.

What's gotten us excited is the noise found in hysteresis loops. Even though they look smooth, hysteresis loops often consist of many small jumps. These jumps can be thought of as the jerk motion of a domain boundary, or as an avalanche of many local spins or domains.

Perturbation Theory

This article is about perturbation theory as a general mathematical method. In mathematics and applied mathematics, **perturbation theory** comprises methods for finding an approximate solution to a problem, by starting from the exact solution of a related, simpler problem. A critical feature of the technique is a middle step that breaks the problem into "solvable" and "perturbative" parts. In perturbation theory, the solution is expressed as a power series in a small parameter ϵ . The first term is the known solution to the solvable problem. Successive terms in the series at higher powers of ϵ usually become smaller. An approximate 'perturbation solution' is obtained by truncating the series, usually by keeping only the first two terms, the solution to the known problem and the 'first order' perturbation correction.”

Perturbation Theory of Quantum Mechanics Or Modern Physics

The author applies the first-order interpolation perturbation method to obtain his “perturbed PPG” waveforms based on one selected carbs/sugar intake amount functioning as the **perturbation factors**, which is the “Slope”. He uses the “measured PPG” waveform as his reference or baseline waveform.

The following polynomial function is used as the perturbation equation:

$$A = f(x) = A_0 + (A_1 * x) + (A_2 * x^{**2}) + (A_3 * x^{**3}) + \dots + (A_n * x^{**n})$$

Where *A* is the perturbed glucose, *A_i* is the measured glucose, and *x* is the perturbation factor based on a chosen carbs/sugar intake amount.

For this particular study, he chooses his *A_i* as *A₁*, where *i*=1. In this way, the above equation can then be simplified into the first-order perturbation equation as follows:

$$A = f(x) = A_0 + (A_1 * x)$$

Or the first-order interpolation perturbation equation can also be expressed in the following general format:

$$A_i = A_1 + (A_2 - A_1) * (\text{slope } 1)$$

Where:

A₁ = original risk *A* at year 1

A₂ = advanced risk *A* at year 2

$(A_2 - A_1) = (\text{Risk } A \text{ at Year } 2 - \text{Risk } A \text{ at Year } 1)$

The perturbation factor or **Slope** is an arbitrarily selected parameter that controls the size of the perturbation. The author has chosen a function of the HbA1C value, as his perturbation factor or slope, which is further defined below:

In this particular study, he would like to use the “perturbation factor” as the combined factor of 77% of MI and 23% of GF.

He selects the lowest value of the combined MI+GF as the low-bound value and the highest value of the combined MI+GF as the high-bound value while using their mid-point value as his selected value.

Then the “slope” becomes

$$\text{Slope} = (\text{Selected value} - \text{Low-bound value}) / (\text{High-bound value} - \text{Low-bound value})$$

Results

Figure 1 displays three waveforms of Cancer risk %, F.FPG, and BW in a time domain and the data table with calculated results of this study.

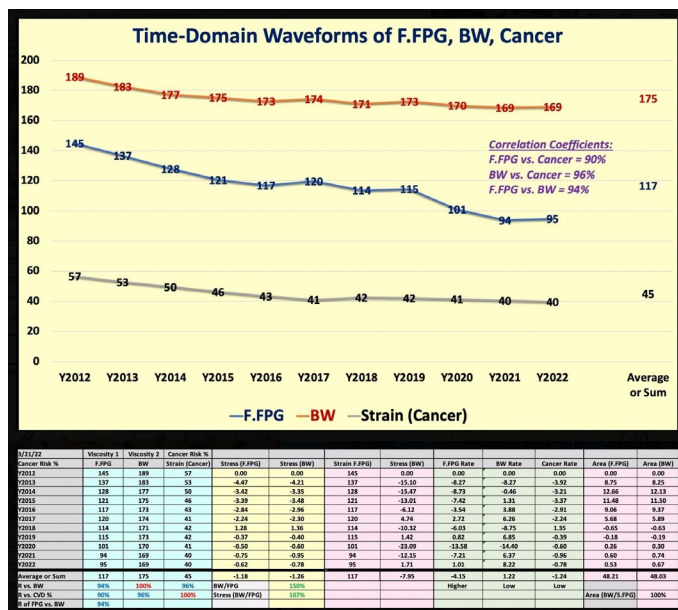

Figure 1: Time-domain waveforms of biomarkers with a data table and calculation results of this study

Figure 2 shows two stress-strain diagrams using 8 semi-annually data space-domain for Cancer risk versus F.FPG / BW, and F.FPG versus BW.

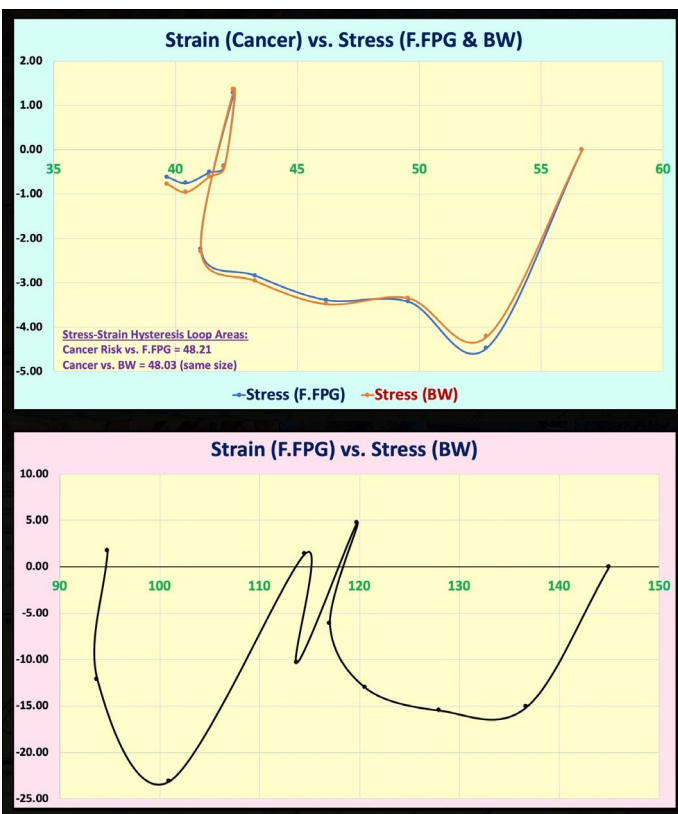

Figure 2: Two stress-strain diagrams in space domain

Figure 3 illustrates a comparison chart between the MI calculated Cancer risk % versus two predicted Cancer risk % using viscoelastic perturbation model. The results have shown high correlations of 95% and extremely high prediction accuracies of 96% - 97%.

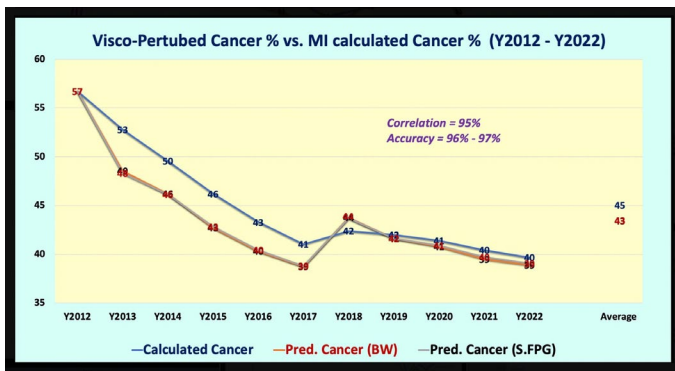

Figure 3: Two Predicted CVD risk % using visco-perturbed model versus calculated Cancer risk % using metabolism model

Conclusion

In summary, the following four described steps show the sequential chain reactions of causes and symptoms in this case study:

- (1) An unhealthy diet and food portion overconsumption with a sedentary lifestyle would cause overweight or obese conditions.
- (2) Most likely, an overweight or obese person would have a higher fasting glucose in the early morning (86% of correlation between BW and FPG based on his data from 10/1/2013 to 3/22/2022).
- (3) FPG serves as an indicator of health state for the pancreatic beta cells (insulin quality and quantity) as well as the baseline of PPG; therefore, a hyper-FPG person most likely would have hyperglycemic conditions (high eAG and high HbA1C).
- (4) Being overweight or having obesity increases the risk of getting cancer. Studies have shown that obesity or overweight is linked with a higher risk of getting 13 types of cancer. These cancers make up 40% of all cancers diagnosed in the United States each year. Many things are associated with cancer, but *avoiding tobacco use and keeping a healthy weight are two of the most important steps you can take to lower your risk of getting cancer. 55 percent of all cancers diagnosed in women and 24 percent of those diagnosed in men are associated with being overweight and obese. A large body of literature indicates that as much as 30% of all cancer cases is linked to poor dietary habits, and is therefore preventable. The proportion reaches 70% for cancers of the gastrointestinal tract. Maintaining a healthy weight throughout life may be one of the most important ways to protect against cancer (US-CDC, June 11, 2007).*

There are five observed conclusions from this research work:

- (1) From the analysis results of both time-domain (biomarker versus time) and space-domain (stress-strain diagrams), *his Cancer risk % (strain) is moving from a high 57% in Y2012 to a lower 40% in Y2022. Both curves have shown viscoplastic behavior (with a big opening of the hysteresis loop).*
- (2) The stress component (equals to Cancer risk change rate

* F.FPG or BW) has two dominating influential components. First, the Cancer change rate indicates the Cancer risk curve fluctuation which determines the curve shape and its moving direction. Besides, his earlier research results and other papers have already demonstrated the importance of glucose fluctuation or glycemic variability (GF or GV) on diabetes control. Second, the viscosity factor (either F.FPG or BW) offers an “amplification or shrinkage” effect on the stress-strain curve which then determines the “magnitude” of the stress-strain curve. That is why he utilizes the normalized F.FPG value and the normalized BW value as his chosen viscosity factors.

(3) These 2 normalized biomarkers, FPG/120 or BW/170, cause the numerical values of the viscosity factors to fall in a very narrow range between 0.x (healthy) to 1.x (unhealthy). This would dampen the original wide range of biomarker data for glucose and weight into a narrow range, but still preserve their inherited biomedical characteristics.

(4) *The areas of two hysteresis loops are 48.21 for stress-strain curve using F.FPG and 48.03 for stress-strain curve using BW (almost identical to each other).* This fact offers proof of the VGT predicted CVD risk can use either normalized F.FPG or normalized BW as its viscosity factor which has no area difference (two energy levels are identical to each other). The same conclusion can also be observed from the visco-perturbed CVD versus the MI calculated CVD in time-domain with 95% correlations and 96% - 97% prediction accuracies.

(5) As a reference, he conducted one additional VGT analysis using F.FPG as the symptom and BW as its cause. This analysis result demonstrated that not only fasting glucose and BW are the causes for Cancer risk, but BW also served as the cause of diabetes conditions (high glucose, particularly high fasting glucose). This example illustrates what he talked about earlier of “m by n by p” matrix.

Obesity, diabetes, and cancers do not occur suddenly, and are usually the result from a patient's unhealthy lifestyle, environmental exposure, or viral infection over a long period of time. About 24% of male cancer patients and 55% of female cancer patients are diagnosed with diabetes as well. Therefore, for patients with both cancers and diabetes, to lower their risks of having cancers, a longer period of continuous efforts on controlling their body weight and lowering their HbA1C is helpful and necessary.

References

For editing purposes, the majority of the references in this paper, which are self-references, have been removed. Only references from other authors' published sources remain. The bibliography of the author's original self-references can be viewed at www.eclairmd.com.

Readers may use this article as long as the work is properly cited, their use is educational and not for profit, and the author's original work is not altered.

Copyright: ©2022 Gerald C. Hsu. This is an open-access article distributed under the terms of the Creative Commons Attribution License, which permits unrestricted use, distribution, and reproduction in any medium, provided the original author and source are credited.