

Viscoelastic or Viscoplastic Glucose Theory (VGT #38): Applying VEGT or VPGT to Study Fasting Plasma Glucose (FPG) Versus Sleep, Weight, and HbA1C to Predict FPG Using Viscoelastic Perturbation Model over 13 Semi-Annual Periods from Y15H2 to Y21H2 Based on the GH-Method: Math-Physical Medicine (No. 619)

Gerald C Hsu

EclaireMD Foundation, USA

***Corresponding author**

Gerald C Hsu, EclaireMD Foundation, USA

Submitted: 15 Junl 2022; Accepted: 20 Jul 2022; Published: 04 Aug 2022

Citation: Gerald C Hsu .(2022). *Viscoelastic or Viscoplastic Glucose Theory (VGT #38): Applying VEGT or VPGT to Study Fasting Plasma Glucose (FPG) Versus Sleep, Weight, and HbA1C to Predict FPG Using Viscoelastic Perturbation Model over 13 Semi-Annual Periods from Y15H2 to Y21H2 Based on the GH-Method: Math-Physical Medicine (No. 619)*. *J App Mat Sci & Engg Res*, 6(2),01-07.

Abstract

Since 2012, the author has been collecting his body weight and finger-piercing glucose values each day. In addition, he accumulates his medical conditions data including blood pressure (BP), heart rate(HR), and blood lipids along with lifestyle details of diet, exercise, sleep, stress, water intake and daily routine details. Based on the collected big data, he organized them into two main groups. The first group is the medical conditions (MC) with 4 categories: weight, glucose, BP, and lipids. The second group is the lifestyle details (LD) with 6 categories: food, exercise, water intake, sleep, stress, and daily routines. For this study, he collects his daily data and then calculates a unique score for each of the 10 categories, including weight ($m1$), sleep score ($m7$), and HbA1C.

In this article, the author applies the viscoelasticity and viscoplasticity theories to conduct his research to discover some hidden behavior or relationship between fasting plasma glucose or FPG (as an output or strain) versus sleep, weight, or HbA1C (as inputs or stresses). The hidden behaviors and relationships between the output biomarker for FPG and the three selected input biomarkers, sleep, weight, and A1C, are time-dependent which change from time to time.

The following two defined equations are used to establish the stress-strain diagram in a space-domain (SD):

strain = ε
= individual FPG value at present semi-annual period

Stress = σ
= $\eta * (d\varepsilon/dt)$
= $\eta * (d\text{-strain}/d\text{-time})$
= (viscosity factor η using individual sleep score, weight, or HbA1C at present semi-annual period) * (FPG at present semi-annual period - FPG at previous semi-annual period)

Next, he applies the viscoelastic perturbation model to calculate the predicted weight.

Perturbed or predicted weight
= strain value (FPG) at present semi-annual period + stress value at present semi-annual period (i.e., FPG change rate * weight, sleep or A1C) * (respective amplification factor)

Where the **amplification factors** are 1.0 for sleep, 170 for weight (using 170 lbs. for body weight = 1.0 as the standard of weight value), and 6.0 for A1C (using 6.0 for A1C as the A1C dividing line between normal condition and diabetic condition). The selected amplification factors create the “differential elements of the stress value” large enough to alter the predicted FPG values.

To offer a simple explanation to readers who do not have a physics or engineering background, the author includes a brief excerpt from Wikipedia regarding the description of basic concepts for elasticity and plasticity theories, viscoelasticity and viscoplasticity theories from the disciplines of engineering and physics in the Method section.

In summary, the following four observations outline the findings from this research work:

(1) From the time-domain (TD) waveforms, his FPG fluctuated between 110 mg/dL - 124 mg/dL during the period of Y15H2 - Y20H1. It then decreased to 91 mg/dL - 97 mg/dL during the period of Y20H2 - Y21H2. This type of TD strain (FPG) variance can also be observed in the SD stress-strain diagrams.

(2) The correlation between FPG and sleep is 73% due to a relative flat line of sleep scores. The correlation between FPG and weight is higher at 89%. The correlation between FPG and A1C is the highest at 93%. This means that the FPG is highly correlated with his body weight (this phenomenon has been observed previously) and HbA1C, where FPG contributes approximately 25% - 30% to HbA1C.

(3) The above observation can be seen in the SD stress-strain diagram as well. All three curves are similar in curve shape's appearance due to the same FPG change rate. However, in SD, his weight and A1C curves are grouped together while his sleep curve is more isolated with a lesser degree of the stress scale. In addition, the three stress-strain curves have demonstrated viscoplastic behavior.

(4) Using a viscoelastic perturbation model, a waveform comparisons study of measured FPG against three predicted FPG waveforms resulting from sleep, weight, and A1C, respectively, can be done. (a) The measured FPG versus the predicted FPG based on sleep has a 97% correlation and 99% prediction accuracy. (b) The measured FPG versus the predicted FPG based on weight has a 93% correlation and 98% prediction accuracy. (c) The measured FPG versus the predicted FPG based on A1C has a 92% correlation and 98% prediction accuracy. **The three sets of high values for both correlation and prediction accuracy have further signified the importance of sleep, weight, and A1C in FPG reduction.**

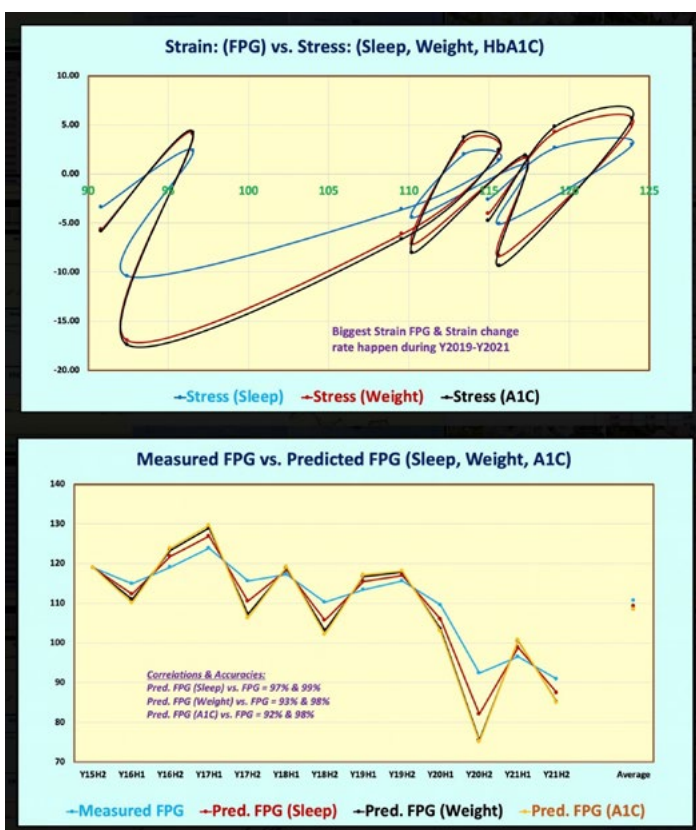

Introduction

Since 2012, the author has been collecting his body weight and finger-piercing glucose values each day. In addition, he accumulates his medical conditions data including blood pressure (BP), heart rate (HR), and blood lipids along with lifestyle details of diet, exercise, sleep, stress, water intake and daily routine details. Based on the collected big data, he organized them into two main groups. The first group is the medical conditions (MC) with 4 categories: weight, glucose, BP, and lipids. The second group is the lifestyle details (LD) with 6 categories: food, ex-

ercise, water intake, sleep, stress, and daily routines. For this study, he collects his daily data and then calculates a unique score for each of the 10 categories, including weight (m1), sleep score (m7), and HbA1C.

In this article, the author applies the viscoelasticity and viscoplasticity theories to conduct his research to discover some hidden behavior or relationship between fasting plasma glucose or FPG (as an output or strain) versus sleep, weight, or HbA1C (as inputs or stresses). The hidden behaviors and relationships between the output biomarker for FPG and the three selected input biomarkers, sleep, weight, and A1C, are time-dependent which change from time to time.

The following two defined equations are used to establish the stress-strain diagram in a space-domain (SD):

$$\text{strain} = \epsilon$$

= individual FPG value at present semi-annual period

$$\text{Stress} = \sigma$$

$$= \eta * (d\epsilon/dt)$$

$$= \eta * (d\text{-strain}/d\text{-time})$$

= (viscosity factor η using individual sleep score, weight, or HbA1C at present semi-annual period) * (FPG at present semi-annual period - FPG at previous semi-annual period)

Next, he applies the viscoelastic perturbation model to calculate the predicted weight.

Perturbed or predicted weight = strain value (FPG) at present semi-annual period + stress value at present semi-annual period (i.e., FPG change rate * weight, sleep or A1C) * (respective amplification factor)

Where the **amplification factors** are 1.0 for sleep, 170 for weight (using 170 lbs. for body weight = 1.0 as the standard of weight

value), and 6.0 for AIC (using 6.0 for AIC as the AIC dividing line between normal condition and diabetic condition). The selected amplification factors create the “differential elements of the stress value” large enough to alter the predicted FPG values.

To offer a simple explanation to readers who do not have a physics or engineering background, the author includes a brief excerpt from Wikipedia regarding the description of basic concepts for elasticity and plasticity theories, viscoelasticity and viscoplasticity theories from the disciplines of engineering and physics in the Method section.

Methods

Elasticity, Plasticity, Viscoelasticity and Viscoplasticity

The Difference Between Elastic Materials and Viscoelastic Materials

(from “Soborthans, innovating shock and vibration solutions”)

What are Elastic Materials?

Elasticity is the tendency of solid materials to return to their original shape after forces are applied on them. When the forces are removed, the object will return to its initial shape and size if the material is elastic.

What are Viscous Materials?

Viscosity is a measure of a fluid’s resistance to flow. A fluid with large viscosity resists motion. A fluid with low viscosity flows. For example, water flows more easily than syrup because it has a lower viscosity. High viscosity materials might include honey, syrups, or gels – generally things that resist flow. Water is a low viscosity material, as it flows readily. Viscous materials are thick or sticky or adhesive. Since heating reduces viscosity, these materials don’t flow easily. For example, warm syrup flows more easily than cold.

What is Viscoelastic?

Viscoelasticity is the property of materials that exhibit both viscous and elastic characteristics when undergoing deformation. Synthetic polymers, wood, and human tissue, as well as metals at high temperature, display significant viscoelastic effects. In some applications, even a small viscoelastic response can be significant.

Elastic Behavior Versus Viscoelastic Behavior

The difference between elastic materials and viscoelastic materials is that viscoelastic materials have a viscosity factor and the elastic ones don’t. Because viscoelastic materials have the viscosity factor, they have a strain rate dependent on time. Purely elastic materials do not dissipate energy (heat) when a load is applied, then removed; however, a viscoelastic substance does.

The following brief introductions are excerpts from Wikipedia:

“Elasticity (Physics)

Physical property when materials or objects return to original shape after deformation

In physics and materials science, **elasticity** is the ability of a body to resist a distorting influence and to return to its original

size and shape when that influence or force is removed. Solid objects will deform when adequate loads are applied to them; if the material is elastic, the object will return to its initial shape and size after removal. This is in contrast to plasticity, in which the object fails to do so and instead remains in its deformed state.

The physical reasons for elastic behavior can be quite different for different materials. In metals, the atomic lattice changes size and shape when forces are applied (energy is added to the system). When forces are removed, the lattice goes back to the original lower energy state. For rubbers and other polymers, elasticity is caused by the stretching of polymer chains when forces are applied.

Hooke’s law states that the force required to deform elastic objects should be directly proportional to the distance of deformation, regardless of how large that distance becomes. This is known as perfect elasticity, in which a given object will return to its original shape no matter how strongly it is deformed. This is an ideal concept only; most materials which possess elasticity in practice remain purely elastic only up to very small deformations, after which plastic (permanent) deformation occurs.

In engineering, the elasticity of a material is quantified by the elastic modulus such as the Young’s modulus, bulk modulus or shear modulus which measure the amount of stress needed to achieve a unit of strain; a higher modulus indicates that the material is harder to deform. The material’s elastic limit or yield strength is the maximum stress that can arise before the onset of plastic deformation.

Plasticity (Physics)

Deformation of a solid material undergoing non-reversible changes of shape in response to applied forces.

In physics and materials science, **plasticity**, also known as **plastic deformation**, is the ability of a solid material to undergo permanent deformation, a non-reversible change of shape in response to applied forces. For example, a solid piece of metal being bent or pounded into a new shape displays plasticity as permanent changes occur within the material itself. In engineering, the transition from elastic behavior to plastic behavior is known as yielding.

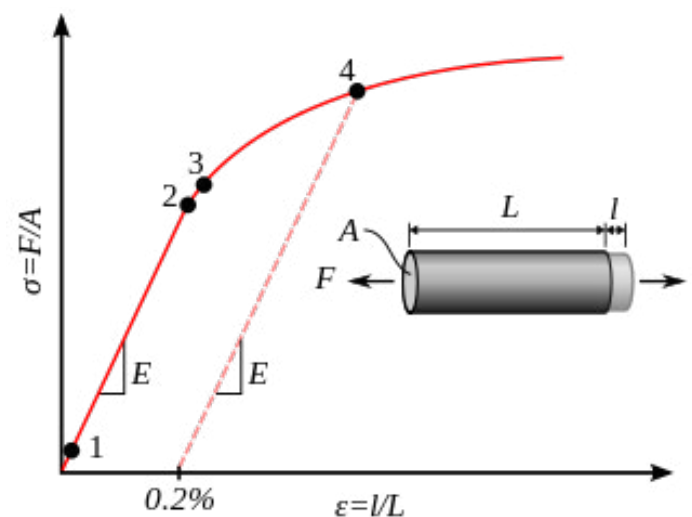

Stress–strain curve showing typical yield behavior for nonferrous alloys.

1. True elastic limit
2. Proportionality limit
3. Elastic limit
4. Offset yield strength

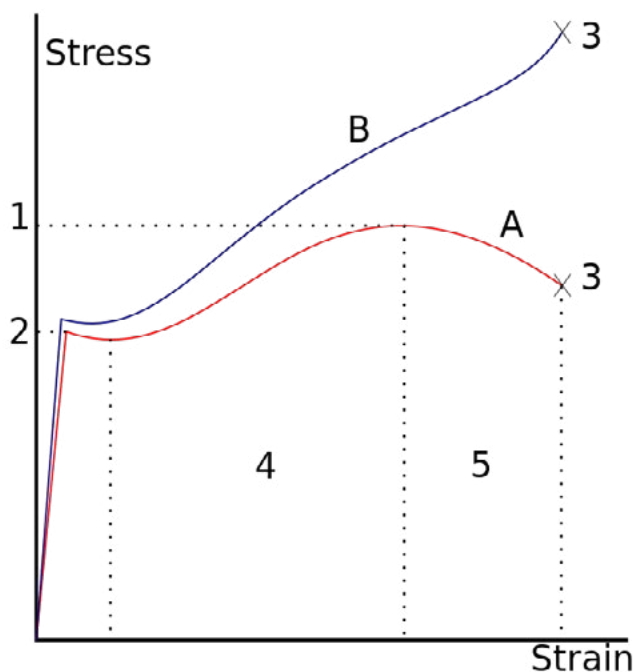

A stress–strain curve typical of structural steel.

- 1: Ultimate strength
- 2: Yield strength (yield point)
- 3: Rupture
- 4: Strain hardening region
- 5: Necking region
- A: Apparent stress (F/A_0)
- B: Actual stress (F/A)

Plastic deformation is observed in most materials, particularly metals, soils, rocks, concrete, and foams. However, the physical mechanisms that cause plastic deformation can vary widely. At a crystalline scale, plasticity in metals is usually a consequence of dislocations. Such defects are relatively rare in most crystalline materials, but are numerous in some and part of their crystal structure; in such cases, plastic crystallinity can result. In brittle materials such as rock, concrete and bone, plasticity is caused predominantly by slip at microcracks. In cellular materials such as liquid foams or biological tissues, plasticity is mainly a consequence of bubble or cell rearrangements, notably TI processes.

For many ductile metals, tensile loading applied to a sample will cause it to behave in an elastic manner. Each increment of load is accompanied by a proportional increment in extension. When the load is removed, the piece returns to its original size. However, once the load exceeds a threshold – the yield strength – the extension increases more rapidly than in the elastic region; now when the load is removed, some degree of extension will remain. Elastic deformation, however, is an approximation and its qual-

ity depends on the time frame considered and loading speed. If, as indicated in the graph opposite, the deformation includes elastic deformation, it is also often referred to as "elasto-plastic deformation" or "elastic-plastic deformation".

Perfect plasticity is a property of materials to undergo irreversible deformation without any increase in stresses or loads. Plastic materials that have been hardened by prior deformation, such as cold forming, may need increasingly higher stresses to deform further. Generally, plastic deformation is also dependent on the deformation speed, i.e. higher stresses usually have to be applied to increase the rate of deformation. Such materials are said to deform visco-plastically."

Viscoelasticity

Property of materials with both viscous and elastic characteristics under deformation

In materials science and continuum mechanics, viscoelasticity is the property of materials that exhibit both viscous and elastic characteristics when undergoing deformation. Viscous materials, like water, resist shear flow and strain linearly with time when a stress is applied. Elastic materials strain when stretched and immediately return to their original state once the stress is removed.

Viscoelastic materials have elements of both of these properties and, as such, exhibit time-dependent strain. Whereas elasticity is usually the result of bond stretching along crystallographic planes in an ordered solid, viscosity is the result of the diffusion of atoms or molecules inside an amorphous material.

In the nineteenth century, physicists such as Maxwell, Boltzmann, and Kelvin researched and experimented with creep and recovery of glasses, metals, and rubbers. Viscoelasticity was further examined in the late twentieth century when synthetic polymers were engineered and used in a variety of applications. Viscoelasticity calculations depend heavily on the viscosity variable, η . The inverse of η is also known as fluidity, ϕ . The value of either can be derived as a function of temperature or as a given value (i.e. for a dashpot).

Depending on the change of strain rate versus stress inside a material, the viscosity can be categorized as having a linear, non-linear, or plastic response. When a material exhibits a linear response it is categorized as a Newtonian material. In this case the stress is linearly proportional to the strain rate. If the material exhibits a non-linear response to the strain rate, it is categorized as Non-Newtonian fluid. There is also an interesting case where the viscosity decreases as the shear/strain rate remains constant. A material which exhibits this type of behavior is known as thixotropic. In addition, when the stress is independent of this strain rate, the material exhibits plastic deformation. Many viscoelastic materials exhibit rubber-like behavior explained by the thermodynamic theory of polymer elasticity.

Cracking occurs when the strain is applied quickly and outside of the elastic limit. Ligaments and tendons are viscoelastic, so the extent of the potential damage to them depends both on the rate of the change of their length as well as on the force applied.

A viscoelastic material has the following properties:

- hysteresis is seen in the stress–strain curve
- stress relaxation occurs: step constant strain causes decreasing stress
- creep occurs: step constant stress causes increasing strain
- its stiffness depends on the strain rate or the stress rate.

Elastic Versus Viscoelastic Behavior

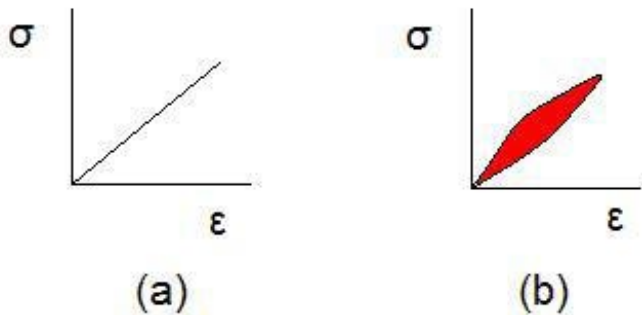

Stress–strain curves for a purely elastic material (a) and a viscoelastic material (b). The red area is a hysteresis loop and shows the amount of energy lost (as heat) in a loading and unloading cycle. It is equal to

$$\oint \sigma d\epsilon$$

where σ is stress and ϵ is strain.

Unlike purely elastic substances, a viscoelastic substance has an elastic component and a viscous component. **The viscosity of a viscoelastic substance gives the substance a strain rate dependence on time.** Purely elastic materials do not dissipate energy (heat) when a load is applied, then removed. However, a viscoelastic substance dissipates energy when a load is **applied, then removed.** Hysteresis is observed in the stress–strain curve, with the area of the loop being equal to the energy lost during the loading cycle. Since viscosity is the resistance to thermally activated plastic deformation, a viscous material will lose energy through a loading cycle. Plastic deformation results in lost energy, which is uncharacteristic of a purely elastic material's reaction to a loading cycle.

Specifically, viscoelasticity is a molecular rearrangement. When a stress is applied to a viscoelastic material such as a polymer, parts of the long polymer chain change positions. This movement or rearrangement is called “**creep**”. Polymers remain a solid material even when these parts of their chains are rearranging in order to accompany the stress, and as this occurs, it creates a back stress in the material. When the back stress is the same magnitude as the applied stress, the material no longer creeps. When the original stress is taken away, the accumulated back stresses will cause the polymer to return to its original form. **The material creeps, which gives the prefix visco-, and the material fully recovers, which gives the suffix -elasticity.**

Viscoplasticity

Viscoplasticity is a theory in continuum mechanics that describes the rate-dependent inelastic behavior of solids. Rate-dependence in this context means that the deformation of the

material depends on the rate at which loads are applied. The inelastic behavior that is the subject of viscoplasticity is plastic deformation which means that the material undergoes unrecoverable deformations when a load level is reached. Rate-dependent plasticity is important for transient plasticity calculations. The main difference between rate-independent plastic and viscoplastic material models is that the latter exhibit not only permanent deformations after the application of loads but continue to undergo a creep flow as a function of time under the influence of the applied load.

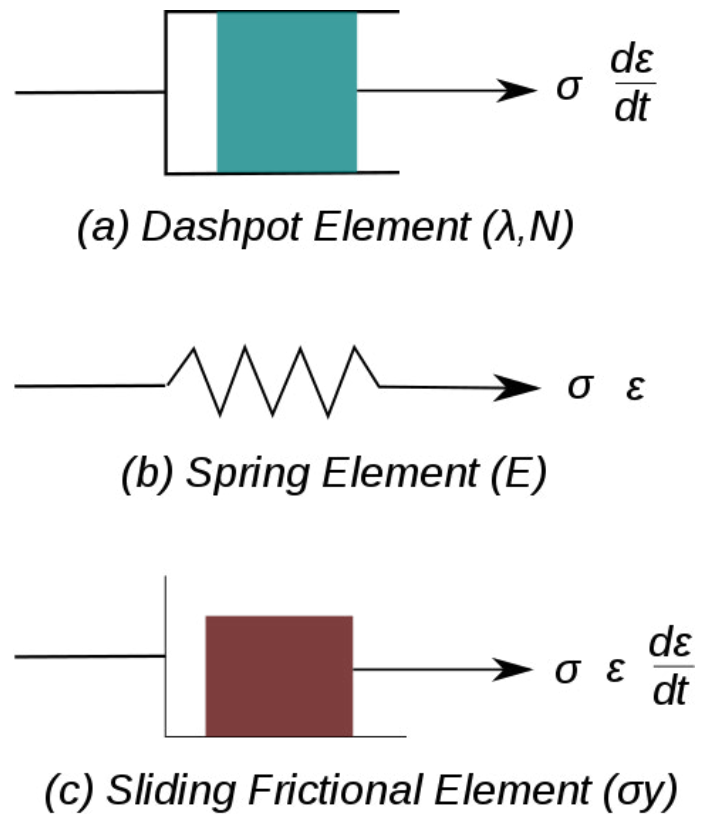

Figure 1: Elements used in one-dimensional models of viscoplastic materials.

The elastic response of viscoplastic materials can be represented in one-dimension by Hookean spring elements. Rate-dependence can be represented by nonlinear dashpot elements in a manner similar to viscoelasticity. Plasticity can be accounted for by adding sliding frictional elements as shown in Figure 1. In the figure E is the modulus of elasticity, λ is the viscosity parameter and N is a power-law type parameter that represents non-linear dashpot [$\sigma(d\epsilon/dt) = \sigma = \lambda(d\epsilon/dt)^{1/N}$]. The sliding element can have a yield stress (σ_y) that is strain rate dependent, or even constant, as shown in Figure 1c.

Viscoplasticity is usually modeled in three-dimensions using overstress models of the Perzyna or Duvaut-Lions types. In these models, the stress is allowed to increase beyond the rate-independent yield surface upon application of a load and then allowed to relax back to the yield surface over time. The yield surface is usually assumed not to be rate-dependent in such models. An alternative approach is to add a strain rate dependence to the yield stress and use the techniques of rate independent plas-

ticity to calculate the response of a material For metals and alloys, viscoplasticity is the macroscopic behavior caused by a mechanism linked to the movement of dislocations in grains, with superposed effects of inter-crystalline gliding. The mechanism usually becomes dominant at temperatures greater than approximately one third of the absolute melting temperature. However, certain alloys exhibit viscoplasticity at room temperature (300K). For polymers, wood, and bitumen, the theory of viscoplasticity is required to describe behavior beyond the limit of elasticity or viscoelasticity.

In general, viscoplasticity theories are useful in areas such as

- the calculation of permanent deformations,
- the prediction of the plastic collapse of structures,
- the investigation of stability,
- crash simulations,
- systems exposed to high temperatures such as turbines in engines, e.g. a power plant,
- dynamic problems and systems exposed to high strain rates.

Phenomenology

For a qualitative analysis, several characteristic tests are performed to describe the phenomenology of viscoplastic materials. Some examples of these tests are

1. hardening tests at constant stress or strain rate,
2. creep tests at constant force, and
3. stress relaxation at constant elongation.

Strain Hardening Test

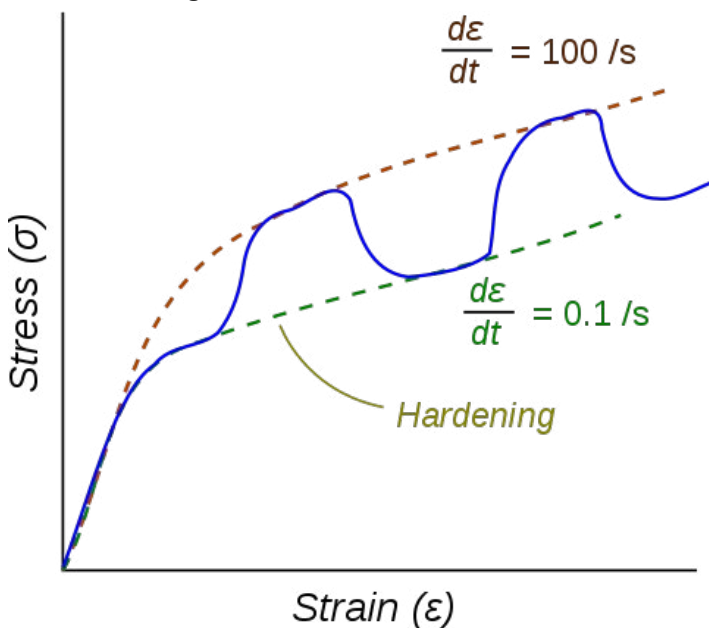

Figure 2: Stress–strain response of a viscoplastic material at different strain rates.

The dotted lines show the response if the strain-rate is held constant. The blue line shows the response when the strain rate is changed suddenly.

One consequence of yielding is that as plastic deformation proceeds, an increase in stress is required to produce additional

strain. This phenomenon is known as Strain/Work hardening. For a viscoplastic material the hardening curves are not significantly different from those of rate-independent plastic material. Nevertheless, three essential differences can be observed.

1. At the same strain, the higher the rate of strain the higher the stress
2. A change in the rate of strain during the test results in an immediate change in the stress–strain curve.
3. The concept of a plastic yield limit is no longer strictly applicable.

The hypothesis of partitioning the strains by decoupling the elastic and plastic parts is still applicable where the strains are small, i.e.,

$$\epsilon = \epsilon_e + \epsilon_{vp}$$

where ϵ_e is the elastic strain and ϵ_{vp} is the viscoplastic strain.

To obtain the stress–strain behavior shown in blue in the figure, the material is initially loaded at a strain rate of 0.1/s. The strain rate is then instantaneously raised to 100/s and held constant at that value for some time. At the end of that time period the strain rate is dropped instantaneously back to 0.1/s and the cycle is continued for increasing values of strain. There is clearly a lag between the strain-rate change and the stress response. This lag is modeled quite accurately by overstress models (such as the Perzyna model) but not by models of rate-independent plasticity that have a rate-dependent yield stress.”

Results

Figure 1 displays the data table and calculated results of this study.

Period	FPG				TD				TD				
	FPG	Sleep	Weight	Daily A1C	FPG	Stress (Sleep)	Stress (Weight)	Stress (A1C)	Period	Measured FPG	Prod. FPG (Sleep)	Prod. FPG (Weight)	Prod. FPG (A1C)
Y17H2	139	0.66	172	7.2	Y17H2	139	0.60	0.60	Y17H2	139	139	139	139
Y18H1	135	0.66	172	7.3	Y18H1	135	2.58	-4.96	Y18H1	135	132	133	136
Y18H2	139	0.60	174	6.9	Y18H2	139	2.65	4.25	Y18H2	139	132	133	134
Y19H1	136	0.67	176	7.0	Y19H1	136	2.89	5.05	Y19H1	136	137	139	140
Y19H2	138	0.62	172	6.8	Y19H2	138	-5.33	-8.87	Y19H2	138	133	137	136
Y20H1	137	0.65	175	6.9	Y20H1	137	3.00	3.64	Y20H1	137	138	139	139
Y20H2	130	0.63	175	6.8	Y20H2	130	-4.68	-7.54	Y20H2	130	136	136	135
Y21H1	133	0.67	172	6.8	Y21H1	133	2.80	3.29	Y21H1	133	135	137	137
Y21H2	136	0.63	173	6.7	Y21H2	136	1.39	2.23	Y21H2	136	137	138	138
Y22H1	130	0.60	172	6.8	Y22H1	130	-3.62	-6.12	Y22H1	130	136	139	139
Y22H2	82	0.61	168	6.2	Y22H2	82	-10.42	-16.96	Y22H2	82	82	91	79
Y23H1	87	0.58	169	6.2	Y23H1	87	2.38	4.05	Y23H1	87	89	100	101
Y23H2	83	0.60	170	6.1	Y23H2	83	-2.80	-5.64	Y23H2	83	87	95	89
Average	131	0.62	173	6.7	Average	131	-9.9	-9.9	Average	131	130	130	130
Correlation	100%	73%	89%	90%	Correlation	100%	14%	14%	Correlation	100%	87%	93%	92%
Accuracy					Accuracy				Accuracy	98%	96%	96%	98%

Figure 1: Data table and calculation results of this study

Figure 2 shows the correlations in TD between FPG versus sleep, weight, and A1C.

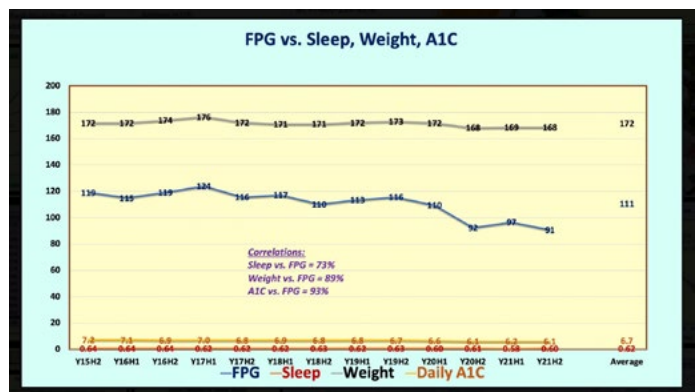

Figure 2: Comparison of FPG vs. sleep, and A1C

Figure 3 depicts the results of a combined stress-strain diagram of FPG versus sleep, weight, and A1C, respectively, using a viscoelastic or viscoplastic theory.

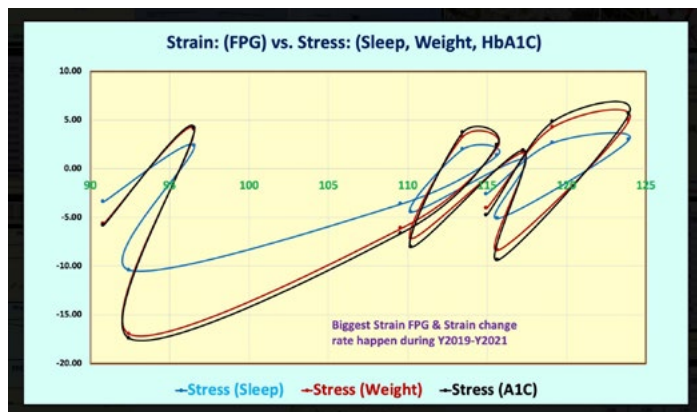

Figure 3: Viscoplastic stress-strain diagrams

Figure 4 reflects the comparison between measured FPG versus three predicted FPG using the viscoelastic perturbation model.

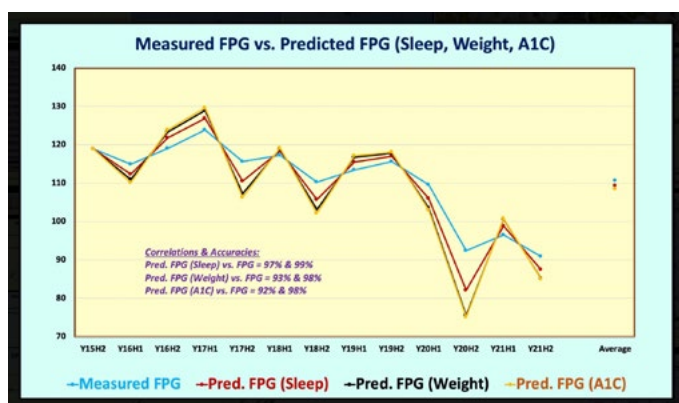

Figure 4: Predicted FPG using a visco-perturbation model vs. measured FPG

Conclusion

In summary, the following four observations outline the findings from this research work:

1. From the TD waveforms, his FPG fluctuated between 110 mg/dL - 124 mg/dL during the period of Y15H2 - Y20H1. It then decreased to 91 mg/dL - 97 mg/dL during the period of Y20H2 - Y21H2. This type of TD strain (FPG) variance can also be observed in the SD stress-strain diagrams.

2. The correlation between FPG and sleep is 73% due to a relative flat line of sleep scores. The correlation between FPG and weight is higher at 89%. The correlation between FPG and A1C is the highest at 93%. This means that the FPG is highly correlated with his body weight (this phenomenon has been observed previously) and HbA1C, where FPG contributes approximately 25% - 30% to HbA1C.
3. The above observation can be seen in the SD stress-strain diagram as well. All three curves are similar in curve shape's appearance due to the same FPG change rate. However, in SD, his weight and A1C curves are grouped together while his sleep curve is more isolated with a lesser degree of the stress scale. In addition, the three stress-strain curves have demonstrated viscoplastic behavior.
4. Using a viscoelastic perturbation model, a waveform comparisons study of measured FPG against three predicted FPG waveforms resulting from sleep, weight, and A1C, respectively, can be done. (a) The measured FPG versus the predicted FPG based on sleep has a 97% correlation and 99% prediction accuracy. (b) The measured FPG versus the predicted FPG based on weight has a 93% correlation and 98% prediction accuracy. (c) The measured FPG versus the predicted FPG based on A1C has a 92% correlation and 98% prediction accuracy. **The three sets of high values for both correlation and prediction accuracy have further signified the importance of sleep, weight, and A1C in FPG reduction.**

References

For editing purposes, the majority of the references in this paper, which are self-references, have been removed. Only references from other authors' published sources remain. The bibliography of the author's original self-references can be viewed at www.eclaircmd.com.

Readers may use this article as long as the work is properly cited, and their use is educational and not for profit, and the author's original work is not altered.

Copyright: ©2022 Gerald C. Hsu., et al. This is an open-access article distributed under the terms of the Creative Commons Attribution License, which permits unrestricted use, distribution, and reproduction in any medium, provided the original author and source are credited.