

Viscoelastic glucose theory (VGT #27): Applying the Concept of Viscoelasticity Theory and using the Estimated Daily Glucose (eAG) over a 3.8-Year Period from 5/8/2018 to 2/17/2022 as the Strain to Study the Role and Influences of the Corresponding Stress as well as their Impact on the Predicted eAG Results Based on the GH-Method: Math-Physical Medicine (No. 608)

Gerald C Hsu

EclaireMD Foundation, USA

***Corresponding author**

Gerald C. Hsu, EclaireMD Foundation, USA

Submitted: 15 Jun 2022; **Accepted:** 20 Jun 2022; **Published:** 30 Jun 2022

Citation: Gerald C Hsu. (2022). *Viscoelastic glucose theory (VGT #27): Applying the Concept of Viscoelasticity Theory and using the Estimated Daily Glucose (eAG) over a 3.8-Year Period from 5/8/2018 to 2/17/2022 as the Strain to Study the Role and Influences of the Corresponding Stress as well as their Impact on the Predicted eAG Results Based on the GH-Method: Math-Physical Medicine (No. 608)*. *J App Mat Sci & Engg Res*, 6(2), 01-08.

Abstract

Recently, the author applied theories of elasticity, plasticity, viscoelasticity, and viscoplasticity from engineering and perturbation theory from quantum mechanics, along with the wave theory and energy theory from physics to conduct his biomedical research on certain output biomarkers, such as glucose (symptoms or behaviors) resulting from a selected input biomarker, such as the carbs/sugar amount, exercise level, or others (causes or stressors).

In this article, he chose his synthesized estimated daily glucose (eAG) data and waveform over the past 3.8 years as the strain (ϵ or output, symptom). Since 5/8/2018, he has been utilizing a continuously monitoring glucose (CGM) sensor device to collect 96 glucose data each day at 15-minute time intervals. In order to investigate and learn the behaviors of the strain (ϵ) or eAG, and its stress (σ) or input/cause as defined to be the eAG change rate multiplied by a selected viscosity factor (η), he purposely select two values of η as 1 and 2. After conducting the stress-strain analysis based on 1 and 2 as his viscosity factors (η), he then uses another set of measured values: average daily carbs/sugar intake amount of 41.13 grams and average daily walking exercise of 16.02 k-steps, as the second set of viscosity factors (η).

There are two main purposes of this research article. First, to check the stress-strain diagram's sensitivity due to the selection of different viscosity factors. Second, to examine the correlation between predicted strain (eAG) waveform using the viscoelastic perturbation model and the measured CGM sensor eAG waveform due to the selection of different viscosity factors.

The following two defined equations from viscoelasticity glucose theory (VGT) are utilized to study the stress-strain relationship for this case study.

At first, he selects his eAG as the strain, which is his target research item:

strain = ϵ
= individual output biomarker value (eAG) at present time

Furthermore, he wants to use the strain rate or his overall eAG change rate to be multiplied by a selected viscosity factor as the stress:

Stress = σ
= $\eta * (d\epsilon/dt)$
= $\eta * (d\text{-strain}/d\text{-time})$

= (viscosity factor η) * ((output biomarker of eAG at present time - output biomarker of eAG at previous time)

Where his four selected viscosity factors (η) are: 1 versus 2, and 41.13 grams versus 16.02 k-steps.

To offer a simple explanation to readers who do not have a physics or engineering background, the author includes a brief excerpt from Wikipedia regarding the description of basic concepts for elasticity and plasticity theories, viscoelasticity and viscoplasticity theories from the disciplines of engineering and physics, along with perturbation theory of quantum mechanics in the Method section.

In summary, the following five observations outline the findings which includes **two sets of his selected viscosity factors: 1 versus 2, and 41 grams of carbs/sugar versus 16 k-steps of daily walking.**

(1) **The selection of eAG as the strain and the strain change rate have determined the basic hysteresis loop shape. However, the selection of viscosity factor only reflects its influence on the scale of the stress (y-axis).**

(2) The trial case of selecting the viscosity factors of 1 and 2 not only reflects the different scales of y-axis (stress), but also reveal a 2:1 ratio of the hysteresis loop areas.

(3) The selected viscosity factor of 2 has resulted in **an amplified effect on predicted eAG** with a lower correlation of 95% in comparison with the viscosity factor of 1 with a higher correlation of 99%.

(4) If he uses his daily average carbs/sugar of 41 grams and average walking of 16 k-steps as his second set of viscosity factors, they will amplify his predicted eAG much more and result in worse correlations of 22% and 41%, respectively. As a matter of fact, **in his previous perturbation analysis, the perturbation has always been less than 100% which would not overly amplify the predicted results.**

(5) Finally, the comparison of his eAG waveform in both time-domain (TD) and spatial-domain (SD) i.e., stress-strain diagram) has shown **4 corresponding regions** i.e., fasting plasma glucose (FPG) sleep (with a zig-zag pattern), breakfast, lunch (highest glucose), dinner and evening. In addition, **the stress-strain diagram indicates a “pseudo-viscoelastic” behavior** which has a hysteresis loop (time-dependent) with both starting eAG and ending eAG close to each other with almost no permanent deformation.

In conclusion, applying VGT and the perturbation theory with a sensitivity study of viscosity factor provides another layer of understanding for eAG behaviors.

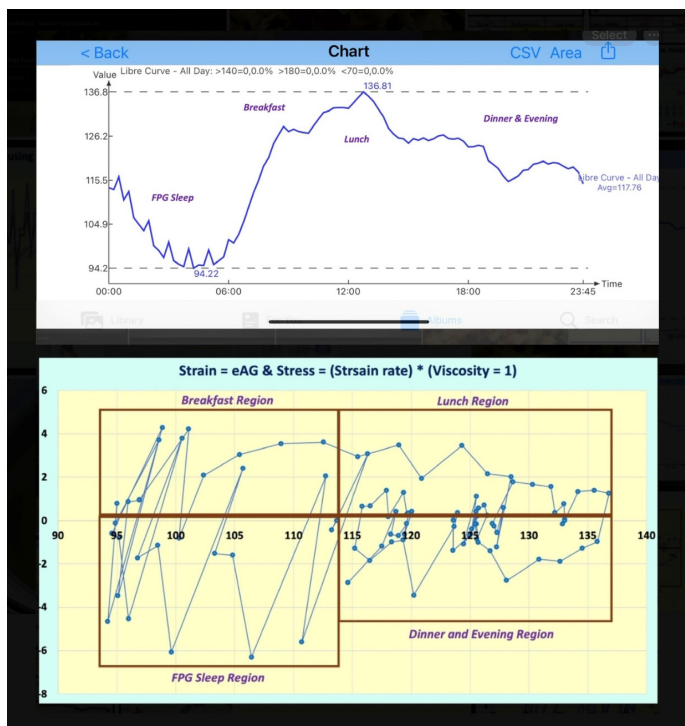

Introduction

Recently, the author applied theories of elasticity, plasticity, viscoelasticity, and viscoplasticity from engineering and perturbation theory from quantum mechanics, along with the wave theory and energy theory from physics to conduct his biomedical research on certain output biomarkers, such as glucose (symptoms or behaviors) resulting from a selected input biomarker,

such as the carbs/sugar amount, exercise level, or others (causes or stressors).

In this article, he chose his synthesized estimated daily glucose (eAG) data and waveform over the past 3.8 years as the strain (ϵ or output, symptom). Since 5/8/2018, he has been utilizing a continuously monitoring glucose (CGM) sensor device to collect 96 glucose data each day at 15-minute time intervals. In order to investigate and learn the behaviors of the strain (ϵ) or eAG, and its stress (σ) or input/cause as defined to be the eAG change rate multiplied by a selected viscosity factor (η), he purposely select two values of η as 1 and 2. After conducting the stress-strain analysis based on 1 and 2 as his viscosity factors (η), he then uses another set of measured values: average daily carbs/sugar intake amount of 41.13 grams and average daily walking exercise of 16.02 k-steps, as the second set of viscosity factors (η).

There are two main purposes of this research article. First, to check the stress-strain diagram's sensitivity due to the selection of different viscosity factors. Second, to examine the correlation between predicted strain (eAG) waveform using the viscoelastic perturbation model and the measured CGM sensor eAG waveform due to the selection of different viscosity factors.

The following two defined equations from viscoelasticity glucose theory (VGT) are utilized to study the stress-strain relationship for this case study.

At first, he selects his eAG as the strain, which is his target research item:

$strain = \epsilon$
 $= individual\ output\ biomarker\ value\ (eAG)\ at\ present\ time$

Furthermore, he wants to use the strain rate or his overall eAG change rate to be multiplied by a selected viscosity factor as the stress:

$Stress = \sigma$
 $= \eta * (d\epsilon/dt)$
 $= \eta * (d-strain/d-time)$
 $= (viscosity\ factor\ \eta) * ((output\ biomarker\ of\ eAG\ at\ present\ time - output\ biomarker\ of\ eAG\ at\ previous\ time)$

Where his four selected viscosity factors (η) are: 1 versus 2, and 41.13 grams versus 16.02 k-steps.

To offer a simple explanation to readers who do not have a physics or engineering background, the author includes a brief excerpt from Wikipedia regarding the description of basic concepts for elasticity and plasticity theories, viscoelasticity and viscoplasticity theories from the disciplines of engineering and physics, along with perturbation theory of quantum mechanics in the Method section.

Methods

Brief Introduction of Math-Physical Medicine (MPM) Research

The author has collected ~3 million data regarding his health condition and lifestyle details over the past 12 years. He spent the entire year of 2014 to develop a metabolism index (MI) model using topology concept, nonlinear algebra, algebraic geometry, and finite element method. This model contains various measured biomarkers and recorded lifestyle details along with their induced new biomedical variables for an additional ~1.5 million data. Detailed data of his body weight, glucose, blood pressure, heart rate, blood lipids, body temperature, and blood oxygen level, along with important lifestyle details, including diet, exercise, sleep, stress, water intake, and daily life routines are included in the MI data base. His developed MI model has a total of 10 categories covering approximately 500 detailed elements that constitute his defined “metabolism model” which are the building blocks or root causes for diabetes and other chronic disease complications, including but not limited to cardiovascular disease (CVD), chronic heart disease (CHD), stroke, chronic kidney disease (CKD), retinopathy, neuropathy, foot ulcer, and hypothyroidism. The end result of the MI development work is a combined MI value within any selected time period with 73.5% as its dividing line between a healthy and unhealthy state. The MI serves as the foundation to many of his follow-up medical research work.

During the period from 2015 to 2017, he focused his research on type 2 diabetes (T2D), especially glucoses, including FPG, postprandial plasma glucose (PPG), eAG, and hemoglobin A1C (HbA1C). During the following period from 2018 to 2022, he concentrated on researching medical complications resulting from diabetes, chronic diseases, and metabolic disorders which include heart problems, stroke, kidney problems, retinopathy, neuropathy, foot ulcer, diabetic skin fungal infection, hypothyroidism, and diabetic constipation, cancer, and dementia. He

also developed a few mathematical risk models to calculate the probability percentages of developing various diabetic complications.

From his previous medical research work, he has identified and learned that those associated energy of hyperglycemia conditions are the primary source of causing many diabetic complications which lead to death. Therefore, a thorough knowledge of these energies is important for achieving a better understanding of those dangerous complications.

Elasticity, Plasticity, Viscoelasticity and Viscoplasticity

The Difference Between Elastic Materials and Viscoelastic Materials

(from “Soborthans, innovating shock and vibration solutions”)

What are Elastic Materials?

Elasticity is the tendency of solid materials to return to their original shape after forces are applied on them. When the forces are removed, the object will return to its initial shape and size if the material is elastic.

What are Viscous Materials?

Viscosity is a measure of a fluid’s resistance to flow. A fluid with large viscosity resists motion. A fluid with low viscosity flows. For example, water flows more easily than syrup because it has a lower viscosity. High viscosity materials might include honey, syrups, or gels – generally things that resist flow. Water is a low viscosity material, as it flows readily. Viscous materials are thick or sticky or adhesive. Since heating reduces viscosity, these materials don’t flow easily. For example, warm syrup flows more easily than cold.

What is Viscoelastic?

Viscoelasticity is the property of materials that exhibit both viscous and elastic characteristics when undergoing deformation. Synthetic polymers, wood, and human tissue, as well as metals at high temperature, display significant viscoelastic effects. In some applications, even a small viscoelastic response can be significant.

Elastic Behavior Versus Viscoelastic Behavior

The difference between elastic materials and viscoelastic materials is that viscoelastic materials have a viscosity factor and the elastic ones don’t. Because viscoelastic materials have the viscosity factor, they have a strain rate dependent on time. Purely elastic materials do not dissipate energy (heat) when a load is applied, then removed; however, a viscoelastic substance does.

The following brief introductions are excerpts from Wikipedia

Elasticity (Physics)

Physical property when materials or objects return to original shape after deformation

In physics and materials science, elasticity is the ability of a body to resist a distorting influence and to return to its original size and shape when that influence or force is removed. Solid objects will deform when adequate loads are applied to them; if the material is elastic, the object will return to its initial shape and size after removal. This is in contrast to plasticity, in which the object fails to do so and instead remains in its deformed state.

The physical reasons for elastic behavior can be quite different for different materials. In metals, the atomic lattice changes size and shape when forces are applied (energy is added to the system). When forces are removed, the lattice goes back to the original lower energy state. For rubbers and other polymers, elasticity is caused by the stretching of polymer chains when forces are applied.

Hooke's law states that the force required to deform elastic objects should be directly proportional to the distance of deformation, regardless of how large that distance becomes. This is known as perfect elasticity, in which a given object will return to its original shape no matter how strongly it is deformed. This is an ideal concept only; most materials which possess elasticity in practice remain purely elastic only up to very small deformations, after which plastic (permanent) deformation occurs.

In engineering, the elasticity of a material is quantified by the elastic modulus such as the Young's modulus, bulk modulus or shear modulus which measure the amount of stress needed to achieve a unit of strain; a higher modulus indicates that the material is harder to deform. The material's elastic limit or yield strength is the maximum stress that can arise before the onset of plastic deformation.

Plasticity (Physics)

Deformation of a solid material undergoing non-reversible changes of shape in response to applied forces.

In physics and materials science, plasticity, also known as plastic deformation, is the ability of a solid material to undergo permanent deformation, a non-reversible change of shape in response to applied forces. For example, a solid piece of metal being bent or pounded into a new shape displays plasticity as permanent changes occur within the material itself. In engineering, the transition from elastic behavior to plastic behavior is known as yielding.

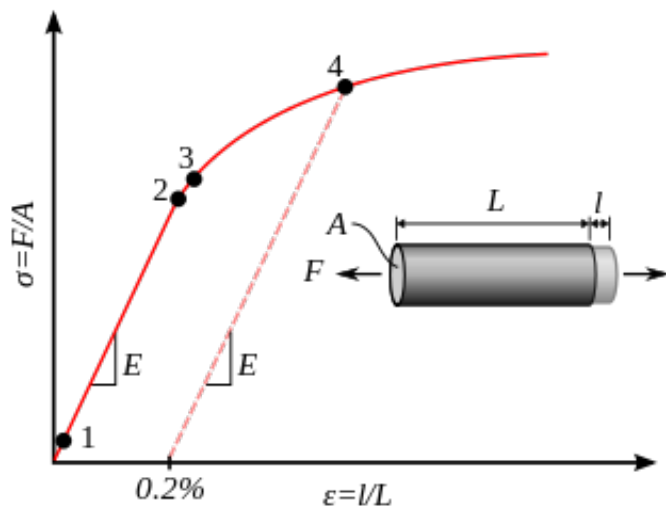

Stress-strain curve showing typical yield behavior for nonferrous alloys.

1. True elastic limit
2. Proportionality limit
3. Elastic limit
4. Offset yield strength

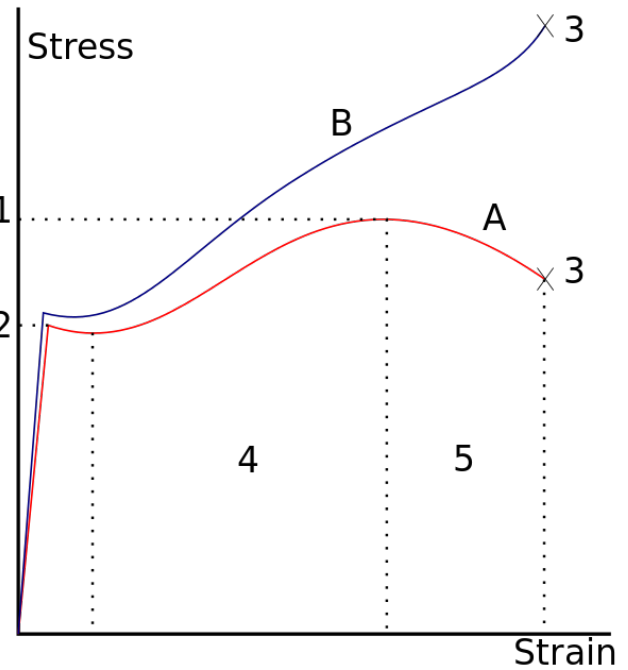

A stress-strain curve typical of structural steel.

- 1: Ultimate strength
- 2: Yield strength (yield point)
- 3: Rupture
- 4: Strain hardening region
- 5: Necking region
- A: Apparent stress (F/A_0)
- B: Actual stress (F/A)

Plastic deformation is observed in most materials, particularly metals, soils, rocks, concrete, and foams. However, the physical mechanisms that cause plastic deformation can vary widely. At a crystalline scale, plasticity in metals is usually a consequence of dislocations. Such defects are relatively rare in most crystalline materials, but are numerous in some and part of their crystal structure; in such cases, plastic crystallinity can result. In brittle materials such as rock, concrete and bone, plasticity is caused predominantly by slip at microcracks. In cellular materials such as liquid foams or biological tissues, plasticity is mainly a consequence of bubble or cell rearrangements, notably T1 processes.

For many ductile metals, tensile loading applied to a sample will cause it to behave in an elastic manner. Each increment of load is accompanied by a proportional increment in extension. When the load is removed, the piece returns to its original size. However, once the load exceeds a threshold – the yield strength – the extension increases more rapidly than in the elastic region; now when the load is removed, some degree of extension will remain.

Elastic deformation, however, is an approximation and its quality depends on the time frame considered and loading speed. If, as indicated in the graph opposite, the deformation includes elastic deformation, it is also often referred to as "elasto-plastic deformation" or "elastic-plastic deformation".

Perfect plasticity is a property of materials to undergo irre-

versible deformation without any increase in stresses or loads. Plastic materials that have been hardened by prior deformation, such as cold forming, may need increasingly higher stresses to deform further. Generally, plastic deformation is also dependent on the deformation speed, i.e. higher stresses usually have to be applied to increase the rate of deformation. Such materials are said to deform visco-plastically.”

Viscoelasticity

Property of materials with both viscous and elastic characteristics under deformation

In materials science and continuum mechanics, viscoelasticity is the property of materials that exhibit both viscous and elastic characteristics when undergoing deformation. Viscous materials, like water, resist shear flow and strain linearly with time when a stress is applied. Elastic materials strain when stretched and immediately return to their original state once the stress is removed.

Viscoelastic materials have elements of both of these properties and, as such, exhibit time-dependent strain. Whereas elasticity is usually the result of bond stretching along crystallographic planes in an ordered solid, viscosity is the result of the diffusion of atoms or molecules inside an amorphous material.

In the nineteenth century, physicists such as Maxwell, Boltzmann, and Kelvin researched and experimented with creep and recovery of glasses, metals, and rubbers. Viscoelasticity was further examined in the late twentieth century when synthetic polymers were engineered and used in a variety of applications. Viscoelasticity calculations depend heavily on the viscosity variable, η . The inverse of η is also known as fluidity, ϕ . The value of either can be derived as a function of temperature or as a given value (i.e. for a dashpot).

Depending on the change of strain rate versus stress inside a material, the viscosity can be categorized as having a linear, non-linear, or plastic response. When a material exhibits a linear response it is categorized as a Newtonian material. In this case the stress is linearly proportional to the strain rate. If the material exhibits a non-linear response to the strain rate, it is categorized as Non-Newtonian fluid. There is also an interesting case where the viscosity decreases as the shear/strain rate remains constant. A material which exhibits this type of behavior is known as thixotropic. In addition, when the stress is independent of this strain rate, the material exhibits plastic deformation. Many viscoelastic materials exhibit rubber like behavior explained by the thermodynamic theory of polymer elasticity.

Cracking occurs when the strain is applied quickly and outside of the elastic limit. Ligaments and tendons are viscoelastic, so the extent of the potential damage to them depends both on the rate of the change of their length as well as on the force applied. **A viscoelastic material has the following properties:**

- hysteresis is seen in the stress–strain curve
- stress relaxation occurs: step constant strain causes decreasing stress
- creep occurs: step constant stress causes increasing strain

- its stiffness depends on the strain rate or the stress rate.

Elastic Versus Viscoelastic Behavior

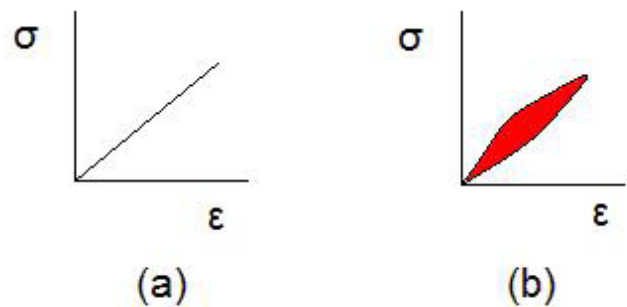

Stress–strain curves for a purely elastic material (a) and a viscoelastic material (b). The red area is a hysteresis loop and shows the amount of energy lost (as heat) in a loading and unloading cycle. It is equal to

$$\oint \sigma d\epsilon$$

where σ is stress and ϵ is strain.

Unlike purely elastic substances, a viscoelastic substance has an elastic component and a viscous component. **The viscosity of a viscoelastic substance gives the substance a strain rate dependence on time.** Purely elastic materials do not dissipate energy (heat) when a load is applied, then removed. However, a viscoelastic substance dissipates energy when a load is **applied, then removed. Hysteresis is observed in the stress–strain curve, with the area of the loop being equal to the energy lost during the loading cycle.** Since viscosity is the resistance to thermally activated plastic deformation, a viscous material will lose energy through a loading cycle. Plastic deformation results in lost energy, which is uncharacteristic of a purely elastic material's reaction to a loading cycle.

Specifically, viscoelasticity is a molecular rearrangement. When a stress is applied to a viscoelastic material such as a polymer, parts of the long polymer chain change positions. This movement or rearrangement is called “creep”. Polymers remain a solid material even when these parts of their chains are rearranging in order to accompany the stress, and as this occurs, it creates a back stress in the material. When the back stress is the same magnitude as the applied stress, the material no longer creeps. When the original stress is taken away, the accumulated back stresses will cause the polymer to return to its original form. **The material creeps, which gives the prefix visco-, and the material fully recovers, which gives the suffix -elasticity.**

Viscoplasticity

Viscoplasticity is a theory in continuum mechanics that describes the rate-dependent inelastic behavior of solids. Rate-dependence in this context means that the deformation of the material depends on the rate at which loads are applied. The inelastic behavior that is the subject of viscoplasticity is plastic deformation which means that the material undergoes unrecoverable deformations when a load level is reached. Rate-dependent plasticity is important for transient plasticity calculations.

The main difference between rate-independent plastic and viscoplastic material models is that the latter exhibit not only permanent deformations after the application of loads but continue to undergo a creep flow as a function of time under the influence of the applied load.

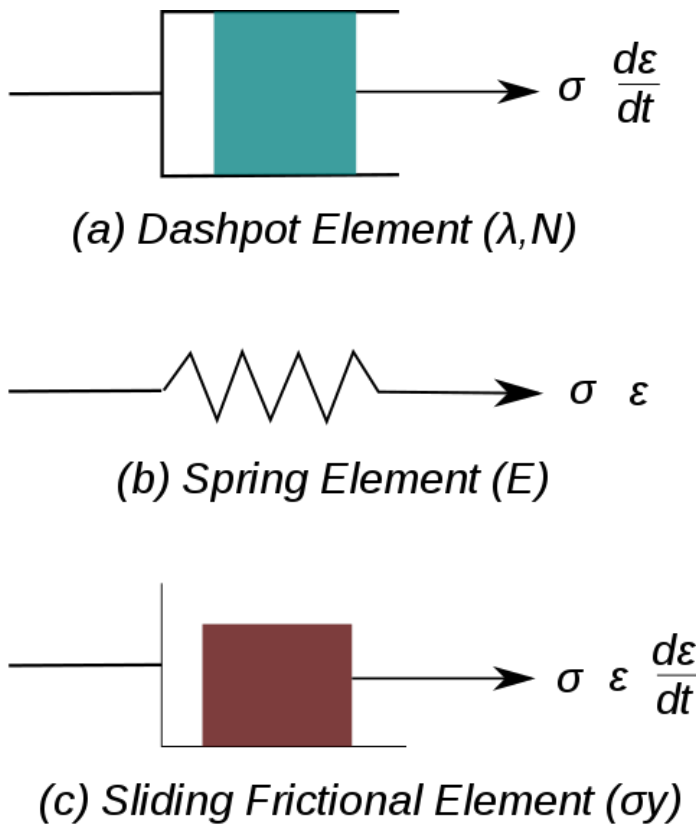

Figure 1. Elements used in one-dimensional models of viscoplastic materials.

The elastic response of viscoplastic materials can be represented in one-dimension by Hookean spring elements. Rate-dependence can be represented by nonlinear dashpot elements in a manner similar to viscoelasticity. Plasticity can be accounted for by adding sliding frictional elements as shown in Figure 1. In the figure E is the modulus of elasticity, λ is the viscosity parameter and N is a power-law type parameter that represents non-linear dashpot [$\sigma(d\epsilon/dt) = \sigma = \lambda(d\epsilon/dt)^{1/N}$]. The sliding element can have a yield stress (σ_y) that is strain rate dependent, or even constant, as shown in Figure 1c.

Viscoplasticity is usually modeled in three-dimensions using overstress models of the Perzyna or Duvaut-Lions types. In these models, the stress is allowed to increase beyond the rate-independent yield surface upon application of a load and then allowed to relax back to the yield surface over time. The yield surface is usually assumed not to be rate-dependent in such models. An alternative approach is to add a strain rate dependence to the yield stress and use the techniques of rate independent plasticity to calculate the response of a material.

For metals and alloys, viscoplasticity is the macroscopic behavior caused by a mechanism linked to the movement of dislocations in grains, with superposed effects of inter-crystalline glid-

ing. The mechanism usually becomes dominant at temperatures greater than approximately one third of the absolute melting temperature. However, certain alloys exhibit viscoplasticity at room temperature (300K). For polymers, wood, and bitumen, the theory of viscoplasticity is required to describe behavior beyond the limit of elasticity or viscoelasticity.

In general, viscoplasticity theories are useful in areas such as

- the calculation of permanent deformations,
- the prediction of the plastic collapse of structures,
- the investigation of stability,
- crash simulations,
- systems exposed to high temperatures such as turbines in engines, e.g. a power plant,
- dynamic problems and systems exposed to high strain rates.

Phenomenology

For a qualitative analysis, several characteristic tests are performed to describe the phenomenology of viscoplastic materials. Some examples of these tests are

1. hardening tests at constant stress or strain rate,
2. creep tests at constant force, and
3. stress relaxation at constant elongation.

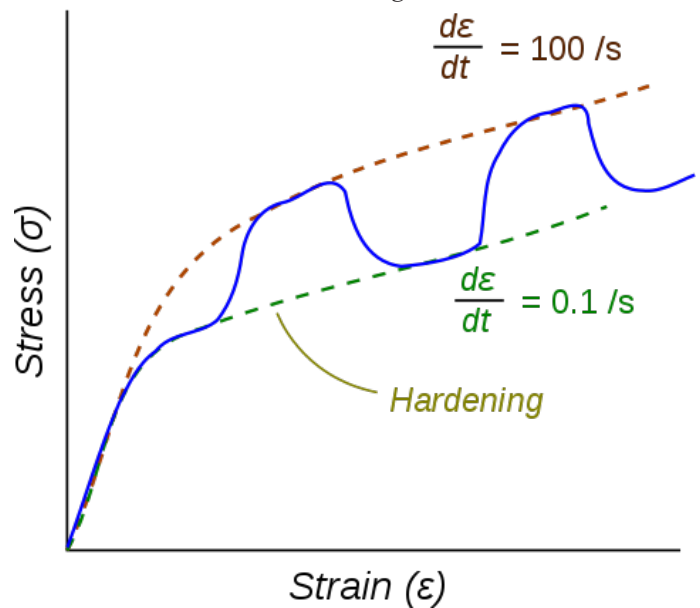

Figure 2. Stress–strain response of a viscoplastic material at different strain rates.

The dotted lines show the response if the strain-rate is held constant. The blue line shows the response when the strain rate is changed suddenly.

One consequence of yielding is that as plastic deformation proceeds, an increase in stress is required to produce additional strain. This phenomenon is known as Strain/Work hardening. For a viscoplastic material the hardening curves are not significantly different from those of rate-independent plastic material. Nevertheless, three essential differences can be observed.

1. At the same strain, the higher the rate of strain the higher the stress
2. A change in the rate of strain during the test results in an immediate change in the stress–strain curve.

3. The concept of a plastic yield limit is no longer strictly applicable.

The hypothesis of partitioning the strains by decoupling the elastic and plastic parts is still applicable where the strains are small, i.e.,

$$\epsilon = \epsilon_e + \epsilon_{vp}$$

where ϵ_e is the elastic strain and ϵ_{vp} is the viscoplastic strain. To obtain the stress-strain behavior shown in blue in the figure, the material is initially loaded at a strain rate of 0.1/s. The strain rate is then instantaneously raised to 100/s and held constant at that value for some time. At the end of that time period the strain rate is dropped instantaneously back to 0.1/s and the cycle is continued for increasing values of strain. There is clearly a lag between the strain-rate change and the stress response. This lag is modeled quite accurately by overstress models (such as the Perzyna model) but not by models of rate-independent plasticity that have a rate-dependent yield stress.

Perturbation Theory

This article is about perturbation theory as a general mathematical method. In mathematics and applied mathematics, **perturbation theory** comprises methods for finding an approximate solution to a problem, by starting from the exact solution of a related, simpler problem. A critical feature of the technique is a middle step that breaks the problem into "solvable" and "perturbative" parts. In perturbation theory, the solution is expressed as a power series in a small parameter ϵ . The first term is the known solution to the solvable problem. Successive terms in the series at higher powers of ϵ usually become smaller. An approximate 'perturbation solution' is obtained by truncating the series, usually by keeping only the first two terms, the solution to the known problem and the 'first order' perturbation correction."

Results

Figure 1 displays two stress-strain diagrams using viscosity factors, $\eta = 1$ and $\eta = 2$, respectively (upper diagram) and its corresponding predicted eAG in TD (lower diagram).

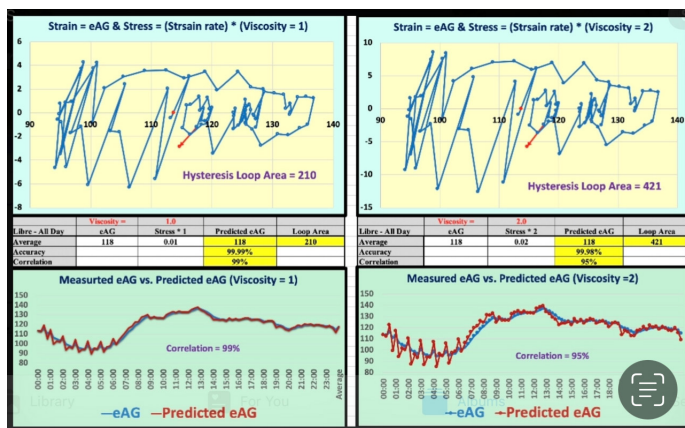

Figure 1: Two eAG stress-strain diagrams (upper diagram) and two predicted eAG in TD (lower diagram) using $\eta = 1$, and 2

Figure 2 depicts two eAG change rates in TD for $\eta = 1$ and 2, respectively. Please note that the waveform amplification effect is a result from $\eta = 2$.

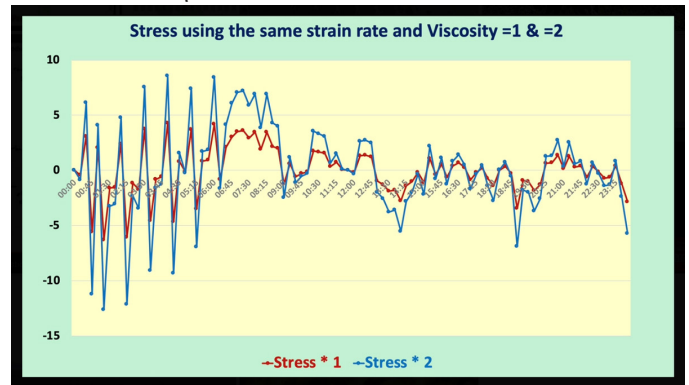

Figure 2: Two eAG change rates in time-domain using $\eta = 1$, and 2

Figure 3 reflects eAG change rates in TD for $\eta = 41.1$ grams and 16.0 k-steps, respectively. Please note that **the same hysteresis loop pattern for a different viscosity factor η .**

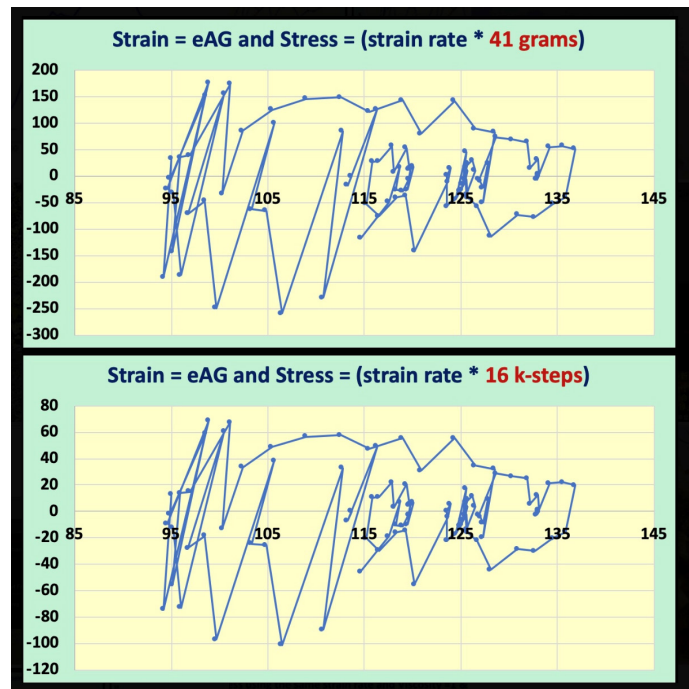

Figure 3: Two eAG stress-strain diagrams using $\eta = 41$ grams, and 16 k-steps, respectively

Figure 4 illustrates the synthesized eAG waveform in TD with four separated regions, FPG sleep, breakfast, lunch, dinner, and evening (upper diagram) along with the corresponding stress-strain diagram with the same four regions (lower diagram).

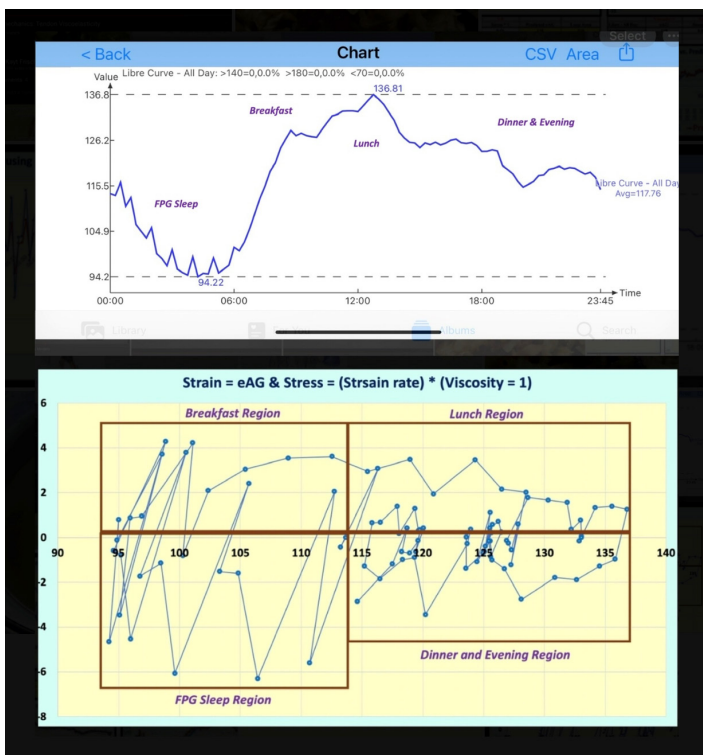

Figure 4: eAG waveform in time-domain and stress-strain diagram in spatial-domain with four regions

Conclusion

In summary, the following five observations outline the findings which includes two sets of his selected viscosity factors: 1 versus 2, and 41 grams of carbs/sugar versus 16 k-steps of daily walking.

(1) The selection of eAG as the strain and the strain change rate have determined the basic hysteresis loop shape. However, the selection of viscosity factor only reflects its influence on the scale of the stress (y-axis).

(2) The trial case of selecting the viscosity factors of 1 and 2 not only reflects the different scales of y-axis (stress), but also reveal a 2:1 ratio of the hysteresis loop areas.

(3) The selected viscosity factor of 2 has resulted in an amplified effect on predicted eAG with a lower correlation of 95% in comparison with the viscosity factor of 1 with a higher correlation of 99%.

(4) If he uses his daily average carbs/sugar of 41 grams and average walking of 16 k-steps as his second set of viscosity factors, they will amplify his predicted eAG much more and result in worse correlations of 22% and 41%, respectively. As a matter of fact, in his previous perturbation analysis, the perturbation has always been less than 100% which would not overly amplify the predicted results.

(5) Finally, the comparison of his eAG waveform in both time-domain (TD) and spatial-domain (SD) i.e., stress-strain diagram has shown 4 corresponding regions i.e., fasting plasma glucose (FPG) sleep (with a zig-zag pattern), breakfast, lunch (highest glucose), dinner and evening. In addition, the stress-strain diagram indicates a “pseudo-viscoelastic” behavior which has a hysteresis loop (time-dependent) with both starting eAG and ending eAG close to each other with almost no permanent deformation.

In conclusion, applying VGT and the perturbation theory with a sensitivity study of viscosity factor provides another layer of understanding for eAG behaviors.

References

For editing purposes, the majority of the references in this paper, which are self-references, have been removed. Only references from other authors' published sources remain. The bibliography of the author's original self-references can be viewed at www.eclairmd.com.

Readers may use this article as long as the work is properly cited, and their use is educational and not for profit, and the author's original work is not altered.

Copyright: ©2022 Gerald C Hsu. This is an open-access article distributed under the terms of the Creative Commons Attribution License, which permits unrestricted use, distribution, and reproduction in any medium, provided the original author and source are credited.