

# Studying Vaccination Coverage and Design of Short Message Service Based Reminder to Improve Children Vaccination Coverage in Hawassa; Sidama Region; Ethiopia

Tamirat Yenealem<sup>1\*</sup>, Dejene Hurissa<sup>1</sup>

<sup>1</sup>Electrical and Computer Engineerin Department, Hawassa University, Ethiopia

\*Corresponding Author

Tamirat Yenealem, Electrical and Computer Engineerin Department, Hawassa University, Ethiopia.

Submitted: 12 Jan 2023; Accepted: 24 Jan 2023; Published: 15 Feb 2023

**Citation:** Yenealem, T., Hurissa, D. (2023). Studying Vaccination Coverage and Design of Short Message Service Based Reminder to Improve Children Vaccination Coverage in Hawassa; Sidama Region; Ethiopia. *Biomed Sci Clin Res*, 2(1), 100-105.

## Abstract

A vaccine is a kind of remedy that trains the body's protection system so that it can combat an infection. The national routine immunization coverage in Ethiopia is low. Among the main reason for defaulting children vaccinations are disremembering the appointment date, communication gap between service providers and the community, knowhow about vaccination and etc. This work is to investigate vaccination coverage in Hawassa city and main reasons of vaccination drop out, and then provide a solution for that main reason. Data was collected from 360 children whose age is between 1 to 2 years who live in Hawassa city. The data analysis result showed that only 51% of the children are fully vaccinated; and the main reason for vaccination dropout which weighs 57% was found to be disremembering the appointment date. Providing a solution to not only one of the main reasons but also for the one which weighs the most in the city of this study will improve the vaccination coverage. As the main reason is found to be disremembering the vaccination appointment date, this work provides a Short Message Service (SMS) based automatic reminding system. The design part uses database, OzekiNG network gateway and global system for mobile communication modem with active subscriber identity module. In this system the health extension workers will register the clients' detailed information including appointment dates during the birth of baby that will be accessed periodically by the OzekiNG to send the reminder SMS to the mothers one day a head to the day of vaccination. After automatic reminding mechanism was developed and implemented, coverage of fully vaccinated children increases from 51% to 71% and the problem of forgetting appointment date decreases from 57% to 14%. The efficiency of the developed system is found to be 85%. From the above mentioned results and the current available communication mechanisms, it can be concluded that the reminding system can be simply implemented to improve the child vaccination coverage by bridging the gap due to disremembering the vaccination appointment date.

**Keywords:** Vaccination, Appointment Date, Immunization, Short Message Service, Vaccination Coverage

## Introduction

Vaccination is the process of giving vaccines to all infants for preventing and eradicating communicable and infectious diseases. Vaccines stimulate a recipient's immune system to produce antibodies that provide future protection against specific diseases. It is among the most effective public health mechanism and added substantial reductions in childhood disease and saving millions of lives throughout the world [1]. Immunization is a very important and has a positive impact on the development of a country as it protects a health of generations. World Health Organization (WHO) supports to the Federal Ministry of Health (FMoH) of Ethiopia through capacity building, staff training, and monitoring mechanism [2]. According to WHO report, Ethiopia is expanding immunization services and applying Expanded Program on Immunization (EPI) as one of the key

programs in WHO Ethiopia under the Maternal, Child Health and Nutrition [2]. The Ethiopian immunization implementation guideline considers children of under-one year of age and women of reproductive age group (15-49 years age) for available EPI vaccines. These vaccines are BCG, Measles, DPT-HepB-Hib or Pentavalent, Rotavirus, PCV, OPV, IPV and TT. The country's immunization schedule for the above listed vaccines strictly follows the WHO recommendations for developing countries [3]. With a resident of about 108 million, Ethiopia is the second most populated country in sub-Saharan Africa [4]. It has vaccination schedules in the region, with six vaccines provided for free to all children through EPI. In Ethiopia the national coverage for basic vaccinations was 39.7% in 2016 and Single vaccination coverage ranged between 53.2% (DTP3) and 69.2% (BCG) [5]. The Ethiopia Mini Demographic and Health Survey 2019 re-

ports national coverage for basic vaccinations is 43.3% with single vaccination coverage ranging between 57.8% (measles) and 74.2% (BCG) [5]. The statics shows that Ethiopia is far below the World Health Organization target of 90% coverage

Various reasons may affect immunization coverage of children in different regions of Ethiopia. According to a qualitative study done at Hadiya zone, southern part of Ethiopia, the main reasons for defaulting from the immunization are missed appointment date(forget) & loss of vaccination card, Inadequate counseling of mothers, Poorly arranged and coordinated immunization services and vaccine of health centers and poor knowledge about immunization and vaccine preventable disease [6].The extraordinary spread of mobile technologies as well as advancements in their innovative application to address health priorities has evolved into a new field of eHealth, known as mHealth [7]. The dissemination of mobile phone networks in many countries surpasses other infrastructure such as cemented roads and energy and the rising of these mobile networks offers high information and data transmission for changing the way health services and information are accessed, delivered, and managed [7]. Mobile technologies ease the life of human being through information and data communication. This work aimed at studying immuni-

zation coverage in hawassa city and design of automatic SMS reminding mechanism for reducing information gap between clients and health institutions.

### Data Collection and Analysis

In this work, the first stage was data collection and analysis to see the degree of defaulting children routine immunization and the reasons of missing of immunization in Hawassa city. In Hawassa city, there are 7 health centers, 2 government hospitals from which data was collected from the health centers side. From the community's side, data was collected from 360 mothers with children whose age is between 12 and 24 months to show child immunization coverage. The collected data is discussed below [7-9].

Figure 1 below shows the ways how children routine vaccinations appointment is given from the health centers as stated by service providers. The result shows that almost all heath institutions include cards that consists of appointment date and 22% of them use phone call to remind residents when they don't show up. But from the customer's perspective, almost two third of the residents revealed that nobody is rying to contact and no mechanism exists to remind them if they forget the appointment date.

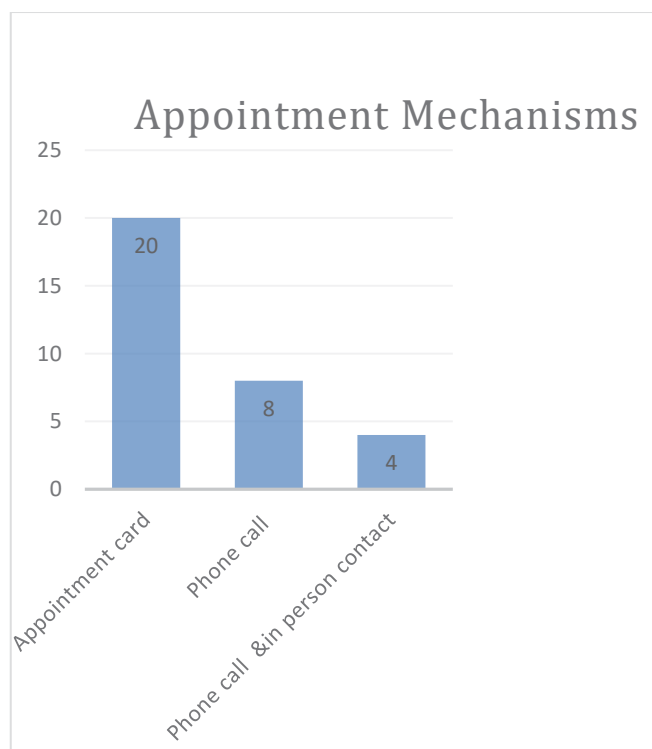
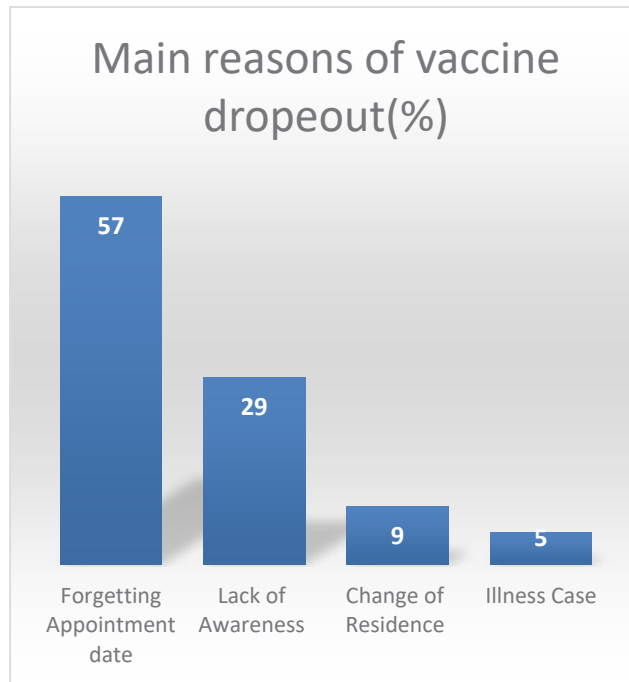

Figure 1: Appointment Reminding Mechanism

Figure 2 presents the main reasons for defaulting children routine vaccinations. The data showed that the major reason is forgetting appointment date which weighs 57%.



**Figure 2:** Main Reasons of Vaccine Dropout Cases

Figure 3 presents the percentage of children vaccine coverage in Hawassa city. It shows that only 51% of children are fully vaccinated and 10% took only one term vaccine. In addition to this,

children who are vaccinated three times weighs 24%, children who took the vaccination twice weighs 15%.

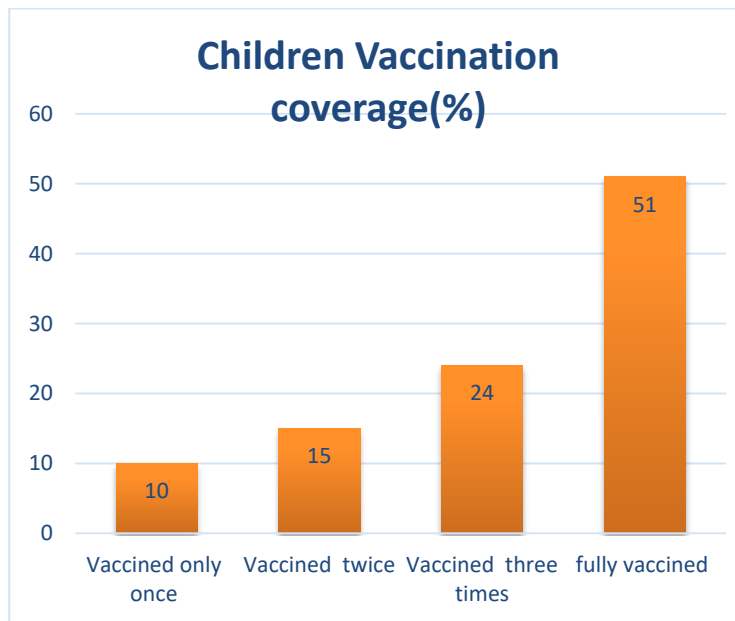

**Figure 3:** Children Vaccination Status

The above data indicates how poor the children vaccination coverage and the major reasons for missing vaccination. Among the reasons, disremembering the appointment date is found to be the main reason for defaulting vaccination and hence bridging this gap will improve the vaccination coverage by providing an appointment date reminding mechanism one day ahead. A very simple mechanism is provided by this work which is discussed below.

### Proposed System

The proposed system which is shown in figure 4 consists of

computer, Ozeki network gateway(ozekiNG) short message service (SMS) Gateway, Database and global system for mobile communication (GSM) modem with Subscriber Identity Module (SIM) card. The installation and working principle are discussed as follows. Firstly, both ozekiNG and SMS gateway and database with database tables and the data entry format are installed and configured. Secondly, database and OzekiNG SMS Gateway are connected. Thirdly, GSM modem with the SIM card is connected to the computer and configured to connect to OzekiNG SMS Gateway. The system has a room for troubleshooting whenever something wrong happens. The system comprises

hardware and software components that help to send messages about vaccination date appointment from health's center to clients/communities through radio waves. This SMS based automatic reminding mechanism system incorporates the use of hardware's such as Computer (Any kind), GSM Modems along with SIM (SIM900A), Mobile phones (Any kind), data cables and 12v dc supply. For successful delivery of the project, software's are very important and it uses Oracle or MS access databases and OzekiNG SMS gateway software. The system uses database for organizing collection of structured information for all clients. The data can then be easily retrieved, managed, improved, reorganized, and organized. Most databases use structured query language (SQL) which is a programming language used by nearly all relational databases to query, operate, and define data, and to offer admission control [8]. This work was demonstrated and piloted using Access Database as it requires only basic computer skills.

The system also uses SMS gateway software called OzekiNG SMS Gateway which provides mobile network connectivity through GSM modem connected to any computer. It offers everything needed from an SMS platform in one engine, with a simple easy to use Web based graphical user interface and others [9]. With the help of this software, it is possible to send SMS messages from access and oracle databases. Depending on mobile network connection, 500 SMS messages per second can be send. It is cool to route and give quick access to the tools you want [9]. The system also contains GSM modem used for transmitting SMS form access or oracle databases to clients. A GSM modem can be connected to a computer through serial, USB or Bluetooth connection. In this project GSM SIM900A Module is used and the service is short message service to customers. Generally, the system presented by this work is planned to fill those gaps and solve the problem of defaulting/missing routine immunization of mothers and children. This system can be used as standalone by itself or integrated with other systems.

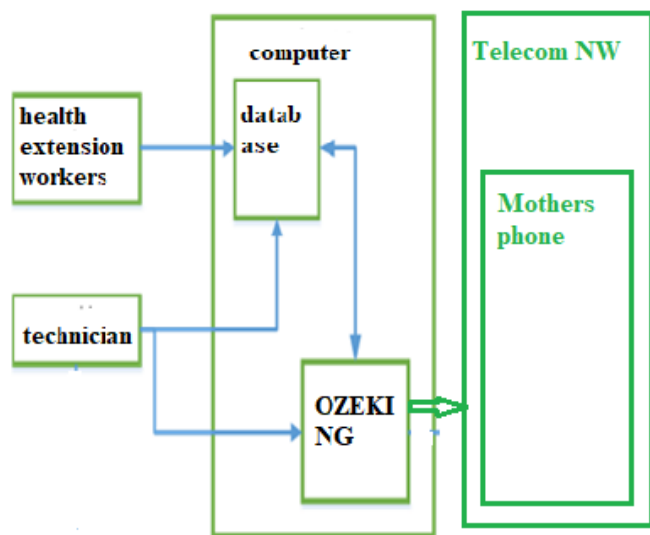

**Figure 4:** The Proposed System

This system is developed to solve the problem of defaulting vaccination due to disremembering the appointment date. i.e., it provides an automatic reminding mechanism through short

message service which is sent to two phone numbers registered as primary and secondary simultaneously one day before the appointment date. The system can be applicable for both urban and rural areas as it does not require internet connection. The database table which is used to enter the child's profile is given by figure 5 below.

**Figure 5:** Data Entry Format of Access Database

At the time of the child birth, the health extension worker will feed the child's profile including the appointment date to be stored in the database. The ozekiNG software will check the appointment dates and send message to the registered family members' phone one day a head to the day of vaccination.

### Piloting Results and Discussion

This is the part where the result of prototype piloting had been observed. The developed system was implemented on health centers for pilot testing. To test the improvement brought by the system, data was collected for the second time after 5 months of implementation. Data was collected from heath institutions, review of averaged manual recorded files of 5 months are used in addition to standard questionnaires to get good generalization from the service providers' side. Data was also collected from residents of the city through interview and questionnaire to discuss the systems effect from the communities' side. Based on the data collected from heath institutions and residences of the city, the following results are obtained.

Figure 6 presents the main reasons for defaulting routine vaccinations after system implementation.

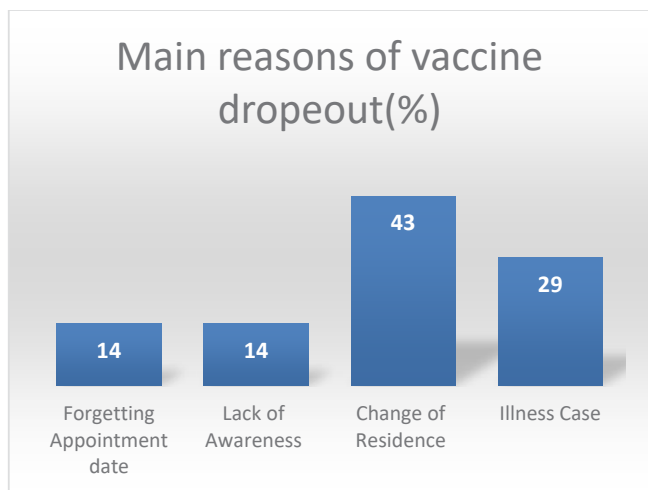

**Figure 6: Main Reasons of Vaccine Dropout Cases**

Based on this data, the status of forgetting appointment date is reduced from 57% to 14%.

Figure 7 reveals the percentage of children vaccine coverage. Based on the data collected after system implementation, the percentage of fully vaccinated children increased from 51% to 71%.

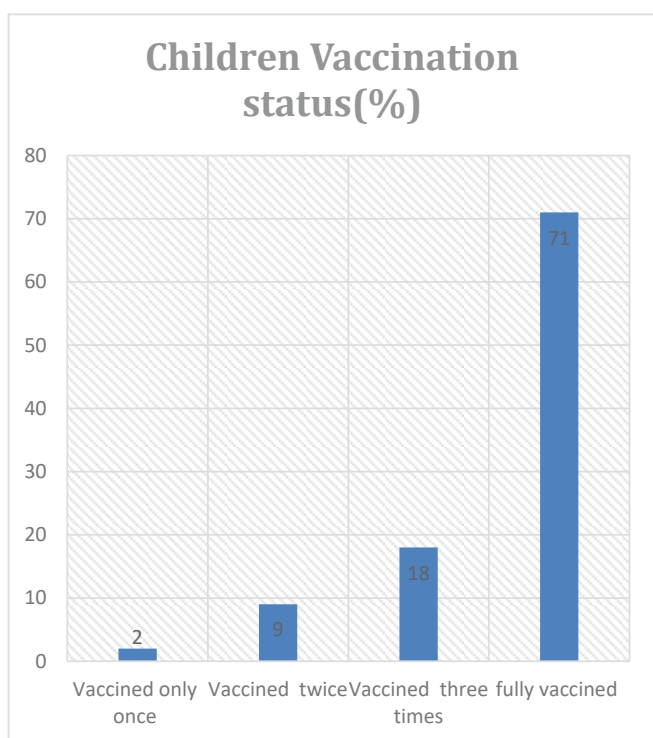
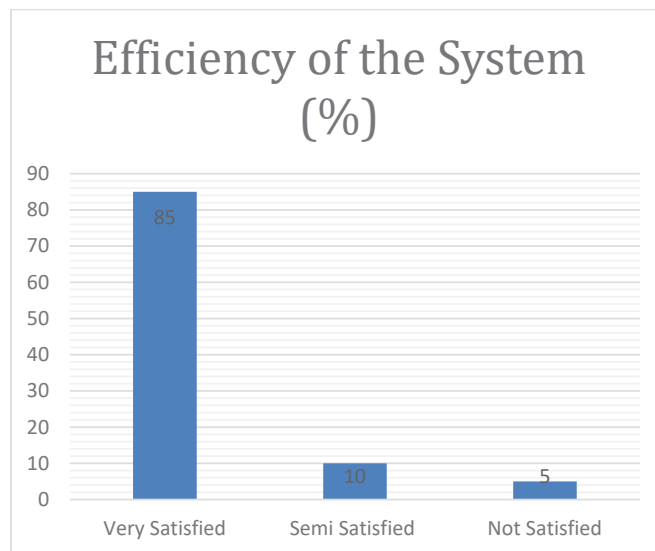

**Figure 7: Children Vaccination Status**

It shows children who are vaccinated three times weighs decreased from 24% to 18% whereas children who took the vaccination twice weighs decreased from 15% to 9%. This indicates that the percentage of full vaccination is increased. Regarding the efficiency of the implemented system, data was collected from health centers and families.

The efficiency of the system is 85% according to the data col-

lected and indicated on figure 8. It enhanced optimum communication between health institutions and residents. Therefore, the system improves the vaccination status which in turn improves the overall community health.



**Figure 8: Efficiency of the System**

### Conclusions

Ethiopia is implementing development and transformation strategy to be middle income country in the next 10 years. Ministry of health is one part of this strategy which is used as an input for the successful accomplishment of this mission. Routine Vaccination is good to have healthy generation. So, both mothers and children are expected to take all vaccinations ordered by WHO. Irrespective of this fact, this study which is done in Hawassa city considers 360 mothers/caretakers' whose children aged between 12 to 24 months and showed that only 51.1% percent of them are fully vaccinated. It's found that one of the major factors for defaulting routine immunization is disremembering the appointment date and missing of appointment card. This work provides a solution to the major reason of defaulting vaccination, which is forgetting the appointment date. As a result, SMS based automatic reminding mechanism is developed to solve this problem. The system improves the problem defaulting vaccination due to forgetting appointment date from 57% to 14% and enhances the level of fully vaccinated children and from 51% to 71%. The efficiency of the developed system is 85%. From the above mentioned results, it can be concluded that the system used in this work is efficient and improves children routine immunization coverage which is one of the goals of WHO and any country's health center.

### Acknowledgments

At the very beginning, we thank GOD for his safeguarding of our personal and academic journeys. During the course of this study, we have received the assistance of many people to whom we are very grateful. First, we like to thank Mr. Zelalem Zenebe, University -Industry- Linkage officer in Hawassa University, for his motivation throughout this work. We also extend our gratitude to SNNPR Regional Health Bureau employees as they were very cooperative in providing the necessary data for this work. We appreciate their positiveness and constructive views. Finally,

---

we express our utmost gratitude to our families and friends who are the main source of motivation.

#### Availability of Data and Materials

The datasets used and analyzed during the current study are available from the corresponding author, Tamirat Yenealem, on reasonable request.

#### References

1. World Health Organization. (2013). Global vaccine action plan 2011-2020.
2. World Health Organization. (1977). Expanded program on immunization.
3. Federal Ministry of Health. (2015). Ethiopia national expanded programme on immunization. Comprehensive multi-year plan 2016-2020.
4. CIA, U. (2016). Central Intelligence Agency-The World Factbook. New Zealand.
5. Geweniger, A., & Abbas, K. M. (2020). Childhood vaccination coverage and equity impact in Ethiopia by socioeconomic, geographic, maternal, and child characteristics. *Vaccine*, 38(20), 3627-3638.
6. Zewdie, A., Letebo, M., & Mekonnen, T. (2016). Reasons for defaulting from childhood immunization program: a qualitative study from Hadiya zone, Southern Ethiopia. *BMC public health*, 16(1), 1-9.
7. World Health Organization. (2011). mHealth: new horizons for health through mobile technologies. mHealth: new horizons for health through mobile technologies.
8. Guru99. "What is Database? What is SQL?" May 1, 2020.
9. OZEKI."OzekiNGSMSGateway,"March12,2020.

**Copyright:**©2023: Tamirat Yenealem. This is an open-access article distributed under the terms of the Creative Commons Attribution License, which permits unrestricted use, distribution, and reproduction in any medium, provided the original author and source are credited.