

Influence of Expeditionary Liqueur on The Formation of Foam Properties of Sparkling Wines

Taranenko V.*, Oseledtseva I., Strukova V.

Kuban State Technological University, 350072, Russian Federation, Krasnodar, 2 Moskovskaya St.

Corresponding author:

Taranenko V, Kuban State Technological University, 350072, Russian Federation, Krasnodar, 2 Moskovskaya St.

Submitted: 30 Dec 2022; Accepted: 06 Jan 2023; Published: 10 Jan 2023.

Citation: Taranenko, V., Oseledtseva, I., Strukova, V. (2023). Influence of Expeditionary Liqueur on The Formation of Foam Properties of Sparkling Wines, *J Huma Soci Scie*, 6(1), 1-9.

Abstract

When determining the quality of sparkling wines, first of all, we thought to focus on the assessment of processes of formation of sparkling and frothy properties, as the process of cavitation reveals the relationship with the chemical components, which affects organoleptic indicators. The effect of expeditionary liquor on frothy properties was investigated and it was found that expeditionary liquor directly affects the concentration of dissolved carbon dioxide. The control samples were made according to the classical technology of sparkling wine production, including "prise de mousse", due to which the carbon dioxide molecules were promoted and dissolved, increasing the degree of diffusion in the liquid. Such a sparkling wine is characterized by a fine foam and a highpressure index. Foam formation is associated with proteins, as they exhibit the ability to adsorb and unfold at the gas-liquid interface, and foam stability is provided by amino acids due to strong bonds that increase wine viscosity. When expeditionary liqueur was added, the pressure dropped from 7 atmospheres to 4 atmospheres, which allowed the sparkling wine to calm down and stabilize bubble formation, and this is the result of the subtle interaction between dissolved carbon dioxide molecules and tensioactive wine components.

Keywords: Expedition Liquor; Foam Properties; Sparkling Wine; Cavitation; Foam Coalescence; Organoleptic Indicators

Introduction

In the production of sparkling wine by classical technology, special attention is paid to the processes of formation of sparkling and frothy properties. The formation of so-called "bubbles" is a very important component not only in winemaking, but also in other scientific fields. For example, in marine science, it is known that when an ocean waves breaks, it can trap air bubbles that burst when they reach the surface, releasing droplets of aerosol into the atmosphere. This mechanism is similarly replicated in a glass of sparkling wine [1].

Chemically speaking, sparkling wines are multi-component aqueous-alcoholic systems, oversaturated with dissolved carbon dioxide molecules. As soon as a bottle of sparkling wine is uncorked, there is a gradual release of dissolved carbon dioxide molecules, capable of re-bubbling, the so-called "boiling" process. It is worth noting that about five liters of carbon dioxide should be released from a typical bottle of sparkling wine of 0.75 liters [2].

"Prise de mousse" is the process of making sparkling wines proper - secondary alcoholic fermentation according to classical technology. During this process the bottles are sealed so that the carbon

dioxide molecules cannot escape and progress by dissolving into the wine. The dissolved carbon dioxide molecules and the carbon dioxide gas molecules under the cork then gradually establish an equilibrium - according to Henry's Law, which states that the partial pressure of a given gas over a solution is proportional to the concentration of the gas dissolved in the solution.

For a given gas, Henry's constant is highly dependent on temperature. The lower the temperature, the higher the Henry's constant and, accordingly, the higher the solubility.

For typical sparkling wine by classical technology the temperature dependence of Henry's law constant, from the thermodynamic point of view is expressed by Vant-Goff equation [3].

Secondary fermentation according to the classic technology produces about 12 g/dm³ of carbon dioxide in each bottle. A typical 750 ml bottle of sparkling wine therefore contains about 9 g of carbon dioxide molecules and a pressure of 5 bar. This amount of dissolved carbon dioxide in the liquid phase is responsible for the formation of bubbles when the bottle is uncorked and the wine is poured into the glass [4,5]. Dissolved carbon dioxide is a very im-

portant parameter because it directly affects the following organoleptic properties: the multiplicity of bubbles formation, the growth rate of rising bubbles, the very characteristic tingling sensation in the mouth and the general olfactory perception of sparkling wines (Kemp B. et al. 2019) [6]. It is important to consider the fact that sparkling wines also contain many compounds originating from grapes and yeast that can influence bubble stability and foam height in the glass [7]. Among them, wine proteins are considered to be important components of sparkling wine foam stability ([8].

The dynamics of protein absorption in the wine matrix and its influence on the formation and stability of foam in sparkling wines are still not fully understood. Foam formation depends on proteins which are characterized by rapid adsorption and unfolding ability at the gas-liquid interface, while foam stability requires proteins to form strong bonds to prevent foam coalescence (Dickinson, E. et al. 1989). Proteins that promote foam formation do not necessarily improve foam stability; they tend to be flexible and have lower molecular weight strength, which leads to the exposure of hydrophobic residues (Dickinson, E. et al. 1989). Meanwhile, amino acids interacting with disulfide bonds are of final importance for stabilization. The presence of free sulfhydryl groups (-SH) are among the main characteristics of foam stabilizers. Different types of proteins can interact with each other, leading to an increase in viscosity, thereby preventing foam coalescence [9].

Foam formation, foam stability, and bubble size in sparkling wines are directly related to surface tension. This can be defined as the force per unit area that maintains the bond between molecules on the surface of the liquid. The presence of surfactants reduces the surface tension of the liquid and allows bubbles to form and persist. After the “prise de mousse”, when the bottle is already open, the difference between the pressure in the bottle and the atmospheric pressure leads to dissolution and the gas spontaneously leaves the liquid. After the pressure on the liquid surface has decreased, balancing with the atmospheric pressure, the bubbles continue to form inside the liquid [10].

It has been proved that grape and yeast polysaccharides can influence the formation and stability of sparkling wine foam, while there is no information on the possible effects of adding exogenous polysaccharide as part of the expedition liquor. The expedition liqueur dosing operation is the final step in the formation of the organoleptic characteristics of the finished sparkling wine [11,12,5,13,14].

At the present time there are no data of scientific research on the effect of exactly polysaccharides formed during the application of expeditionary liquor on the foaming ability. Research in this area is concentrated on the study of individual components. The duration of foam is directly related to the stability of bubbles, and the stability itself depends on the composition of the wine which supports it. In sparkling wines, bubbles consist of gas surrounded by a wrap of wine constituents. These tensioactive components and other sub-stable compounds impart viscosity to the wrap, giving

texture to the bubble. The potential of foam properties has been shown to depend on the composition of surface tension-reducing compounds and those compounds that increase the viscosity of the wrap between the bubbles. This factor contributes to foam stabilization [5].

Surface tension reducing compounds are produced during autolysis of the yeast. However, prolonged aging is expensive so inactivated dry yeast (IDY), for example, is used as an additional source of proteins, mannoproteins and polysaccharides; mannoproteins as polysaccharides of yeast cell walls; exopolysaccharide produced by yeast as monosaccharide constituents [15,16,12].

During foam formation, protein can rapidly adsorb at the air-water interface, reducing surface tension, increasing the viscoelasticity of the liquid phase, eventually forming a stabilized wrap. In view of this, protein can stabilize the foam over a longer time scale because of the formation of highly elastic networks on the bubble surface compared to low molecular weight surfactants [17].

Compounds that increase the viscosity of the wrap between the bubbles are surfactants because they act on the surface between the two phases. Molecules of such substances, such as lecithin, or other amino acids, have two separate parts contained in the same molecule: one of which is water soluble and the other insoluble.

Today in the scientific literature the results of studies on the influence of different doses of sucrose on the froth properties of sparkling wines are presented. The results of these studies show that increasing the sucrose concentration improves the foaming, but reduces the stability of the foam [18-21]. It should be noted that the expedition liqueur, as a source of sugars, also contains volatile components, phenolic compounds and amino acids. Expeditionary liqueur is produced from the same vintage as sparkling wine. When sucrose and sulfiting agent are added to this wine material, all components of the chemical composition are concentrated and preserved, which provides a balanced content according to the main indicators: volume fraction of ethyl alcohol, mass concentration of sugars, volatile acids and titratable acids.

There is scientific evidence that the use of some substances as additives does not give a persistent long-term result, as the effect of these substances in fact was short-lived and hyperbolized. That is, they enhance the effect of frothy properties, but quickly reduce the potential of new bubble formation and level the sparkling performance and worsen the visual assessment of sparkling wine [22].

Expedition liqueur is traditionally regarded as “Similia similibus curantur” because it is prepared from the same wine material. Concentrated grape must, which is added instead of expedition liqueur, has the same effect; this method will reduce labor intensity of the process and ensure consistency of organoleptic indicators [22].

The purpose of the study was to evaluate the significant effect of expeditionary liqueur in increasing concentrations on the compo-

sition and foaming characteristics of sparkling wine of bottle fermentation.

Material and Methods

The materials used were a sparkling wine aged cuvée (brut) of Pinot Franc, grown in the “ZSV “Novy Svet” (Republic of Crimea, Sudak) and working versions of the expeditionary liqueur with the following conditions: the mass concentration of sugars 70g/100cm³, the volume fraction of ethyl alcohol 11.5%, the mass concentration of titratable acids 7.0 g/dm³.

The liqueur production technology involved mixing high quality wine material with sucrose by dissolving sugar while stirring and aging. Dosage of expedition liqueur: for extra brut - 4 g/dm³; for brut (brut) - 12 g/dm³; for dry (extra dru) - 20 g/dm³; for semi-dry (sec) - 35 g/dm³; for semi-sweet (demi sec) - 50 g/dm³.

Researches were carried out by a hardware-software complex “Foam-forming analyzer” and a method of measuring of foaming ability indicator of wine material, developed in Kuban State Technological University (KubGTU). Analysis of foaming ability was carried out by instrumental method.

The method is based on measuring the average value of the maximum volume of foam of the analyzed wine sample, formed as a result of passing a controlled flow of carbon dioxide through a certain volume of the sample [23].

The method of determining on the analyzer investigated criterion makes it possible to record the dynamics of formation and destruction of foam in automatic mode, with the calculation of the foaming capacity index.

The analyzer includes sets of carbon dioxide flow meters, actuators, a microcontroller and a personal computer with specially designed software. Figure 1 shows the scheme of “Foam analyzer”. The method of measurement on the analyzer of the criterion under study makes it possible to record the dynamics of formation and destruction of foam in automatic mode, which is displayed on the monitor in the form of a graph, with the calculation of the foam-forming capacity index.

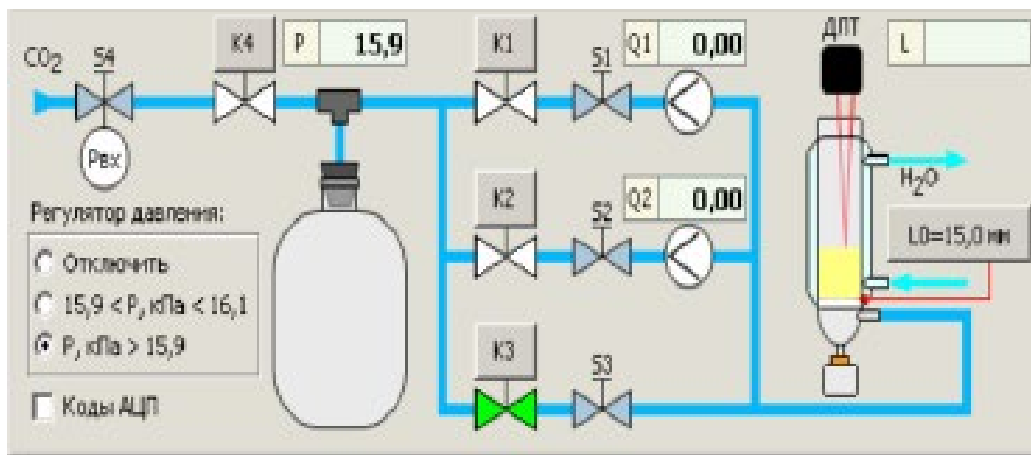

Figure 1: Schematic diagram of the foaming capacity analyzer

During the analysis, the picture of the formation and destruction of foam is displayed in real time, by the nature of which you can predict the state of surfactants in wine.

Calculation of the instrumental method

The dynamic method for determining the foaming capacity of various fluids, by which the average volume of foam is proportional to the rate of gas flow through the fluid, is determined by formula 1:

$$H = f \frac{V}{\tau}; \quad (1)$$

where H - is the average value of the maximum foam volume;
V - is the volume of gas that has passed through the liquid in time τ ;
f - coefficient of proportionality, the value constant for each foaming liquid.

The foaming capacity index is determined by formula 2:

$$F = \frac{H_F}{V}; \quad (2)$$

It was found that the process of foam formation on the surface of sparkling wine passes through three successive stages.

In the beginning, the foam is formed by an intense but short-lived gas flow. At this stage, the main mass of foam is formed, gradually reaching a limit volume, depending on the initial pressure, temperature and composition of the wine.

The second stage is characterized by the stabilization of the foam layer because an equilibrium is established between the volume of foam being formed and the volume being destroyed. The main

condition characterizing this stage is observance of equilibrium, defined by the formula 3:

$$\frac{V_p}{V_g} = \text{const}; \quad (3)$$

where V_p - is the equilibrium volume of foam;
 V_g - volume of CO₂ emitted from wine per unit time.

At this stage, which is characteristic of sparkling wine and determines its frothy qualities, the process depends on the content of bound carbon dioxide and surfactants in the wine and on the factors determining the size of bubble breakaway diameters, the number of active cavitation nuclei, the growth and popping rate of bubbles.

The third stage begins when the volume of foam on the surface of the champagne begins to decrease, when the rate of new formation of foam becomes less than the rate of its destruction. This happens during the decaying period because of the significant decrease in the concentration gradient of carbon dioxide. The volume of foam on the wine surface in this case decreases until its complete disintegration. Only the second stage is of practical importance for characterizing the frothy properties of Champagne wines. In addition to the visual effect, the foaminess of the wine contributes to the perception of the finest tones of the bouquet and the taste of the wine [24].

In addition to the instrumental method, a visual evaluation of the foaming ability was additionally carried out.

Objects

Studies were carried out in the laboratory conditions of the Department of technology of winemaking, fermentation, sugar and food flavoring products named after Professor A. A. Merzhanian FGBOU VO "KubGTU".

Experimental samples of sparkling wines: sample №1 - "Cuvée" - control sample, without adding liqueur; sample №2 - extra brut, liqueur dosage at the rate of 4 g/dm³; sample №3 - brut, liqueur dosage at the rate of 12 g/dm³; sample №4 - dry, liqueur dosage at the rate of 20 g/dm³; sample №5 - semi-dry, liqueur dosage at the rate of 35 g/dm³; sample №6 - semi-sweet, liqueur dosage at the rate of 50 g/dm³. Total number of experimental samples - 15 (at the rate of three variants for each sample).

Results and Discussion

Expedition liqueur is a sugar-containing product made from bottled wine material, or a blend of wine materials, or wine after secondary fermentation with the addition of granulated sugar or white sugar of high purity (without betaine alkaloid) and one or more

organic acids (citric, L-apple, DL-apple, lactic acid) and, if necessary, cognac distillate.

Instrumental Method

According to the experimental results received by us at dosage of forwarding liqueur for production of sparkling wine extra brut, brut, dry, semi-dry and semi-sweet in experimental samples reduction of foaming ability to: D = 16,5s; Hmax = 69,3mm; F = 10,2 was observed (Appendix Fig. 1,2). Samples 3 to 5 had an average value of foaming capacity (Appendix Figures 3-5), while the control sample, in which the expedition liquor was not dosed, had a maximum foaming capacity: D = 28 s; Hmax = 98.9mm; F = 25.7 (Appendix Figure 6). The control sample was characterized by the following features: pungent aroma, aggressive play in the glass, sharp tingling on the tongue, which corresponds to the indicators of sparkling wine of dry bottle fermentation.

It is known that the formation and persistence of foam directly depend on the chemical composition of sparkling wine and synergistic interaction between numerous active blowing agents, which because of the combined formation or complexation can change their surfactant properties. In this case proteins, peptides, amino acids, polysaccharides, phenolic compounds, lipids, organic acids have the greatest influence [25].

According to our earlier research the ability of control samples to foam is directly correlated with their chemical composition, which is subject to change under the influence of expeditionary liquor, with the greatest influence in this case have amino acids and proteins, which are associated with the physical parameters of foam [26].

A study of the effect of experimental dosages of expeditionary liqueur on foaming ability revealed that wine proteins break down after dosage application. Sparkling wines contain more or less surface active macromolecules from grapes and yeast, which have a fundamental role in the duration and quality of bubbles in the glass. From birth, the bubbles are charged with carbon dioxide, and their growth is directly related to the concentration of carbon dioxide dissolved in the wine. It then separates from its place of formation and rises to the surface. During its journey, it captures surface-active molecules in the wine. When the bubbles reach the surface of the wine, the surface-active macromolecules have their protective role, prolonging the life span of the bubble and thereby promoting ring formation.

Non Instrumental Method

In addition to the instrumental method, visual assessment of foaming was carried out, which was recorded on quality photographic tape for 1-10 seconds. The results of the observation confirm the data obtained by the instrumental method (Figures 2-7).



Figure 2 : Foaming capacity in sample №1



Figure 3: Foaming capacity in sample №2



Figure 4: Foaming capacity in sample №3

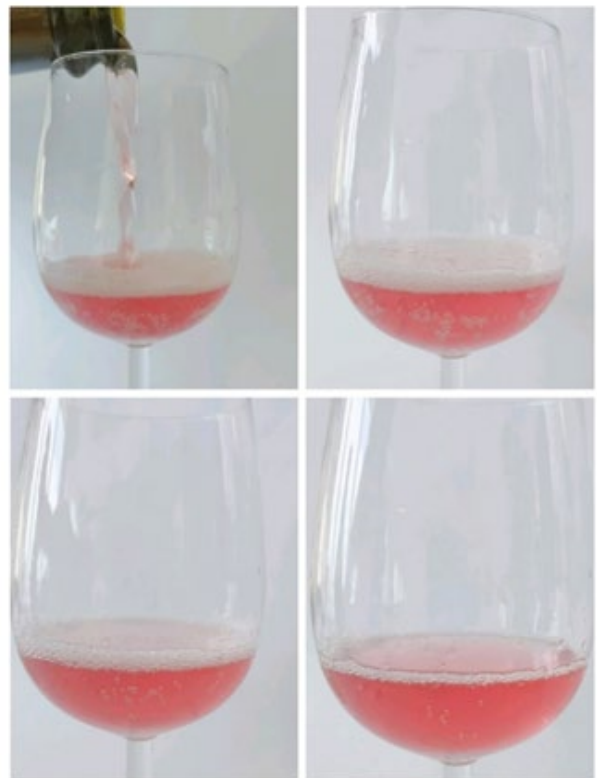

Figure 5: Foaming capacity in sample №4



Figure 6 : Foaming capacity in sample №5

It is known that despite the low protein concentration in the experimental samples (4 to 16 mg/dm³), during foam stabilization because of deposition at the bubble edge, the hydrophobic side of the protein interacts with the gas phase, and the hydrophilic side, interacts with the aqueous liquid phase. The behavior of proteins in foam depends on their hydrophobicity, solubility, and molecular weight. The isoelectric point of wine proteins is between 3.5 and 4.5 [27]. According to these data, when adding expedition liqueur to the experimental samples at the rate of: for extra brut (extra brut) - 4g/dm³; for brut (brut) - 12 g/dm³; for dry (extra dru) - 20 g/dm³; for semi-dry (sec) - 35 g/dm³; for semi-sweet (demi sec) - 50 g/dm³, there is a decrease to the pH level to 2.9. At the same time, it is found that under these conditions, stabilization of foam is observed. This may be explained by the fact that at a wine pH of 2.9 its proteins, as a rule, have a positive charge and can migrate to the wine-air interface, thereby stabilizing the foam. In this way, foam stabilization is achieved, which is visually clearly recorded in samples №5 and №6.

According to the data we obtained, the control samples into which expedition liquor was added were characterized by a higher density ring of bubbles, which remained stable for at least 30 minutes after foam stabilization. It was established experimentally that the foaming ability of the reference sample directly depended on the



Figure 7 : Foaming capacity in sample №6

pressure in the bottle: when the pressure in the bottle dropped because of the addition of expedition liquor from 7 to 4 atmospheres, the reduction of sparkling properties and activation of cavitation processes were observed.

Considering the fact that the formation of bubbles in sparkling wine is practically similar to the formation of bubbles in marine foam: in both cases, individual bubbles on the surface burst, myriads of bubbles rising upwards, collapse and spray over the surface a lot of tiny droplets, creating refreshing aerosols, the mechanism of diffusion of flavors will also be similar. Oceanographers have proved that in marine foam bubbles carry surface-active substances - surfactants, which are released to the ocean surface as an aerosol, increasing the aroma of freshness. The same characteristic "fizz" is similar for sparkling wine, which in turn allows revealing much more aromas than in a quiet wine [28-31].

Conclusions.

So it was established that the addition of expeditionary liquor in general contributes to an increase in the foaming ability of the finished sparkling wine because of the tensioactive components, which impart texture to the bubbly. When dosing the expedition liqueur in an amount of 35 g/dm³ and 50 g/dm³ the control samples were characterized by a crown over the wine surface, covering it

completely, with bubbles two or three lines deep, which was maintained by the cavitation process for half an hour as a result of pressure reduction in the bottle. This result is explained by the fact that the introduction of the expedition liquor allowed the surfactants to rise more easily from the liquid and pass into aerosols, resulting in the samples having a "chemical imprint" with the disclosed aroma of sparkling wine.

Experimentally it was found that expeditionary liqueur can be used as a tool to regulate the taste by eliminating harshness and coarseness with the possibility of prolonging the frothy and sparkling properties.

Appendices

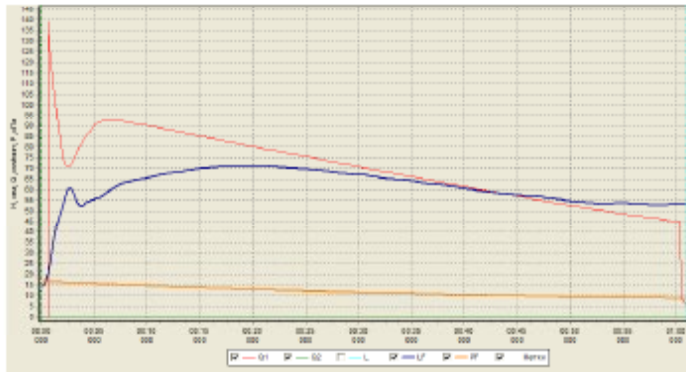

Figure 1: Foaming capacity in sample No. 6

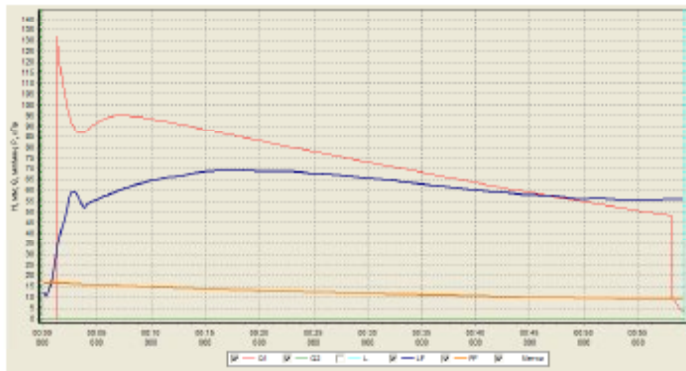

Figure 2: Foaming capacity in sample No. 5

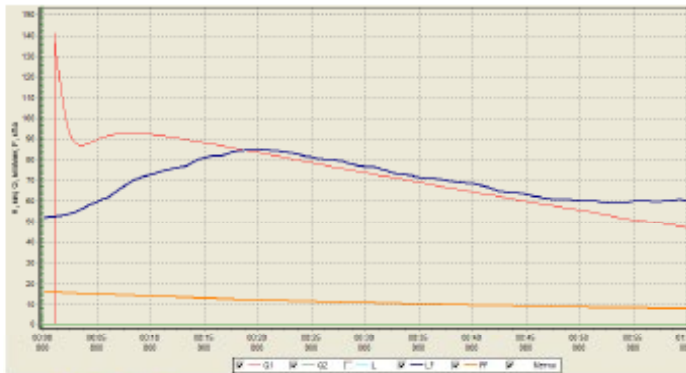

Figure 3: Foaming capacity in sample No. 4

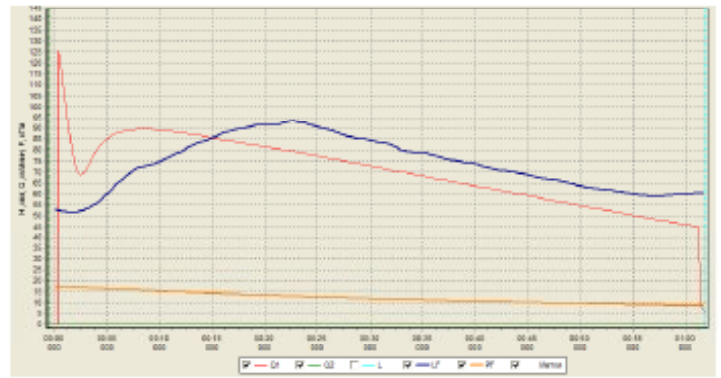

Figure 4 - Foaming capacity in sample No. 3

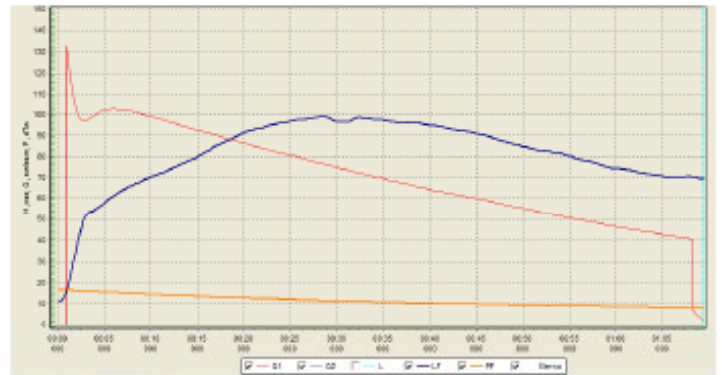

Figure 5 - Foaming capacity in sample No. 2

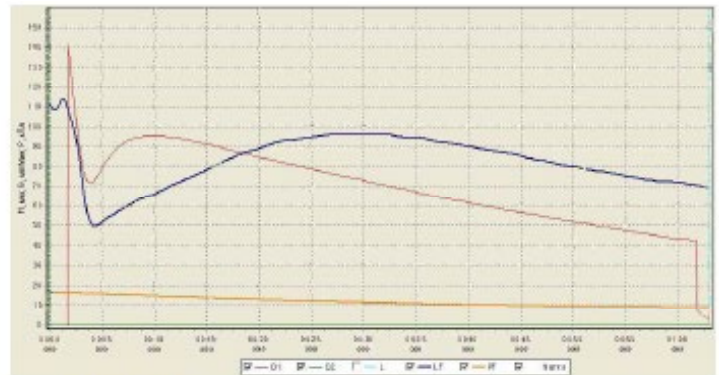

Figure 6 : Foaming capacity in sample No. 1

Author contributions

Vlada Taranenko performed writing – original draft and conceptualization. Inna Oseledtseva and Vera Strukova performed writing – review and editing.

This research did not receive any specific grant from funding agencies in the public, commercial, or not-for-profit sectors.

Conflicts of Interest: The authors declare no conflict of interest.

References

1. OIV's Focus. The sparkling wine market. [Internet]. 2017. Available from: <http://www.oiv.int/public/medias/3098/les-vins-effervescents-en-complet.pdf>
2. Liger-Belair, G. (2004). *Uncorked: The Science of Champagne* (Revised Edition). Princeton, New Jersey. Princeton University.
3. Alexandre H, Guilloux-Benatier M. Yeast autolysis in sparkling wine. A review. *Australian Journal of Grape and Wine Research*. 2006; 12:119-127. DOI: 10.1111/j.1755-0238.2006.tb00051.x
4. [Esteruelas, M., González-Royo, E., Gil, M., Kountoudakis, N., Orte, A., Cantos, A., ... & Zamora, F. \(2015\). Influence of temperature during the second fermentation and aging of sparkling wine \(Cava\) on the properties of the foam. In BIO Web of Conferences \(Vol. 5, p. 02011\). EDP Sciences.](#)
5. Liger-Belair, G. (2017). Effervescence in champagne and sparkling wines: From grape harvest to bubble rise. *The European Physical Journal Special Topics*, 226(1), 3-116.
6. Kemp, B., Condé, B., Jégou, S., Howell, K., Vasserot, Y., & Marchal, R. (2019). Chemical compounds and mechanisms involved in the formation and stabilization of foam in sparkling wines. *Critical reviews in food science and nutrition*, 59(13), 2072-2094.
7. [Cilindre, C., Fasoli, E., D'Amato, A., Liger-Belair, G., & Righetti, P. G. \(2014\). It's time to pop a cork on champagne's proteome!. *Journal of Proteomics*, 105, 351-362.](#)
8. Condé, B. C., Bouchard, E., Culbert, J. A., Wilkinson, K. L., Fuentes, S., & Howell, K. S. (2017). Soluble protein and amino acid content affects the foam quality of sparkling wine. *Journal of agricultural and food chemistry*, 65(41), 9110-9119.
9. Dickinson, E. (1989). Protein adsorption at liquid interfaces and the relationship to foam stability. In *Foams: Physics, chemistry and structure* (pp. 39-53). Springer, London.3
10. Buxaderas, S., & López-Tamames, E. (2012). Sparkling wines: Features and trends from tradition. *Advances in food and nutrition research*, 66, 1-45.
11. Kemp, B., Alexandre, H., Robillard, B., & Marchal, R. (2015). Effect of production phase on bottle-fermented sparkling wine quality. *Journal of Agricultural and Food Chemistry*, 63(1), 19-38.
12. [Cilindre, C., Liger-Belair, G., Villaume, S., Jeandet, P., & Marchal, R. \(2010\). Foaming properties of various Champagne wines depending on several parameters: Grape variety, aging, protein and CO2 content. *Analytica chimica acta*, 660\(1-2\), 164-170.](#)
13. Liger-Belair, G., Marchal, R., Robillard, B., Vignes-Adler, M., Maujean, A., & Jeandet, P. (1999). Study of effervescence in a glass of champagne: Frequencies of bubble formation, growth rates, and velocities of rising bubbles. *American journal of enology and viticulture*, 50(3), 317-323.
14. Kemp, B., Condé, B., Jégou, S., Howell, K., Vasserot, Y., & Marchal, R. (2019). Chemical compounds and mechanisms involved in the formation and stabilization of foam in sparkling wines. *Critical reviews in food science and nutrition*, 59(13), 2072-2094.
15. [Martínez-Lapuente, L., Guadalupe, Z., Ayestarán, B., Ortega-Heras, M., & Pérez-Magariño, S. \(2013\). Changes in polysaccharide composition during sparkling wine making and aging. *Journal of agricultural and food chemistry*, 61\(50\), 12362-12373.](#)
16. [Dikit, P., Maneerat, S., & H-kittikun, A. \(2012\). Mannoprotein from spent yeast obtained from Thai traditional liquor distillation: Extraction and characterization. *Journal of Food Process Engineering*, 35\(1\), 166-177.](#)
17. Chen, F. P., Li, B. S., & Tang, C. H. (2015). Nanocomplexation between curcumin and soy protein isolate: Influence on curcumin stability/bioaccessibility and in vitro protein digestibility. *Journal of Agricultural and Food Chemistry*, 63(13), 3559-3569.
18. Onda, T., Komatsu, M., & Nakayama, T. (2022). Impact of Addition of Sugar on the Final Process of Domestic Sparkling Wine Making. *JOURNAL OF THE JAPANESE SOCIETY FOR FOOD SCIENCE AND TECHNOLOGY-NIPPON SHOKUHIN KAGAKU KOGAKU KAISHI*, 69(4), 155-162.
19. [De Iseppi, A., Marangon, M., Vincenzi, S., Lomolino, G., Curioni, A., & Divol, B. \(2021\). A novel approach for the valorization of wine lees as a source of compounds able to modify wine properties. *LWT*, 136, 110274.](#)
20. [Sanyurek, N. K., Ince, O. K., Aydogdu, B., & Ince, M. \(2021\). Determination of Antioxidant Capacity, Phenolic and Elemental Composition in Syriac \(Mardin\) Wines by using Chromatographic and Spectrophotometric Methods. *Analytical Chemistry Letters*, 11\(1\), 55-72.](#)
21. [Francioli, S., Guerra, M., López-Tamames, E., Guadayoi, J. M., & Caixach, J. \(1999\). Aroma of sparkling wines by head-space/solid phase microextraction and gas chromatography/mass spectrometry. *American journal of enology and viticulture*, 50\(4\), 404-408.](#)
22. [Dragan V. \(RU\), Tartus V. \(RU\), Method of production of Muscat Sparkling White Wine, RU2010107308/10A, 2010-03-01.](#)
23. Mishin M. A new method for assessing the foaming ability of table wine materials for sparkling wines / М.В.Мишин, О.Р.Таланян //Виноделие и виноградарство. -№2.- 2013. – с.16-18.
24. Adolfo M.-R. et al Autolytic capacity and Foam Analysis as Additional criteria for sparkling wine production // *Food Microbiology*. – 2001. – v. 18. – N 2. – p. 183-191.
25. Marchal, R., Jeandet, P., & Robillard, B. (2007). *Macromolecules and champagne wine foaming properties: A review. Macromolecules and Secondary Metabolites of Grapevine and Wines*. Paris: Intercept Lavoisier, 349-370.
26. Taranenko, V., Oseledtseva, I., & Strukova, V. (2022). Influence of expeditionary liqueur on the formation of foam properties of sparkling wines.
27. Martínez-Lapuente, L., Guadalupe, Z., Ayestarán, B., & Pérez-Magariño, S. (2015). Role of major wine constituents in the foam properties of white and rosé sparkling wines. *Food Chemistry*, 174, 330-338.

-
28. Cochran, R. E., Ryder, O. S., Grassian, V. H., & Prather, K. A. (2017). Sea spray aerosol: The chemical link between the oceans, atmosphere, and climate. *Accounts of chemical research*, 50(3), 599-604.
 29. Coelho, E., Reis, A., Domingues, M. R. M., Rocha, S. M., & Coimbra, M. A. (2011). Synergistic effect of high and low molecular weight molecules in the foamability and foam stability of sparkling wines. *Journal of agricultural and food chemistry*, 59(7), 3168-3179.
 30. Moreno-Arribas, V., Pueyo, E., Nieto, F. J., Martín-Álvarez, P. J., & Polo, M. C. (2000). Influence of the polysaccharides and the nitrogen compounds on foaming properties of sparkling wines. *Food Chemistry*, 70(3), 309-317.
 31. Vincenzi, S., Crapisi, A., & Curioni, A. (2014). Foamability of Prosecco wine: Cooperative effects of high molecular weight glycoconjugates and wine PR-proteins. *Food Hydrocolloids*, 34, 202-207.

Copyright: ©2023 Taranenko V. This is an open-access article distributed under the terms of the Creative Commons Attribution License, which permits unrestricted use, distribution, and reproduction in any medium, provided the original author and source are credited.