

# A New Model for Correcting and Improving the Sequence Networks Method of Single-Phase Earth Fault to Accommodate All Resistance Grounding Systems

Yubo Wang

Independent Technical Researcher, Shanghai, PRC.

**\*Corresponding author**

Yubo Wang, Independent Technical Researcher, Shanghai, PRC, China.

**Submitted:** 08 Feb 2023; **Accepted:** 13 Feb 2023; **Published:** 21 Feb 2023

**Citation:** Wang, Y. (2023). A New Model for Correcting and Improving the Sequence Networks Method of Single-Phase Earth Fault to Accommodate All Resistance Grounding Systems. *J Math Techniques Comput Math*, 2(2), 117-126.

**Abstract**

The method of sequence networks is still well-known and widely utilized for analyzing and computing unsymmetrical faults in power system networks today, particularly in solid grounding systems where it was initially introduced for short circuit analysis. When it comes to single-phase earth fault that is a dominant majority type of fault in power distribution grids, different neutral grounding methods with varied impedances result in distinct fault characteristics, to continue utilizing sequence networks could cause inaccurate calculations by the reason of neutral voltage during earth fault does not remain as close to zero as it's pinned in solid grounding system. As neutral resistance increases gradually, the impact of line-to-ground capacitance becomes more pronounced and can no longer be ignored. In this case, applying sequence networks could lead to calculated results that are far from the actual situations in grids. This paper discovers and proves an obscurely hidden defect of the sequence network, while proposing a new and novel modeling to derive comprehensive equations of fault calculations for all types of resistant grounding systems, including solid grounding, low resistance grounding, high resistance grounding, and ungrounded systems.

**Key Words:** Sequence Networks, Asymmetrical Systems, Earth Fault, Neutral Resistance, Fault Current, Neutral Voltage, Zero-Sequence Voltage at Fault, Phase-To-Ground Capacitance, Fault Impedance.

**Background**

When asymmetrical faults occur in power systems, thanks to symmetrical components method, the unbalanced system can be decomposed into three independent systems: the positive-sequence, negative-sequence, and zero-sequence systems. The positive-sequence system corresponds to the positive-sequence components of voltage and current, the negative-sequence system to the negative-sequence components, and the zero-sequence system to the zero-sequence components. Through an "ingenious" mathematical trick, the formula of fault current at the fault point can be derived, which surprisingly reveals that the equivalent networks of the three sequence systems have relations "in series" in a mathematical sense. This further leads to the classical model of sequence networks for single-phase earth fault, which is adopted as a fundamental tool for fault analysis in almost all textbooks of power system analysis.

Any theoretical model is indispensable for the study of practical problems, but when the theory deviates from reality or makes a wrong interpretation, it means that the object under study cannot be reasonably abstracted, simplified, and summarized with its essential characteristics, and thus cannot play a real effective role in practical applications. The sequence networks, as a basic theoretical model of power systems, have been around for

a long time. The earliest utilization was in the solidly grounded transmission and distribution networks. As grid scale expansion, line density, and conflicts between lines and external space substances in the medium-voltage distribution network increased, the solid grounding application could no longer meet the protection demand, so ungrounded, low resistance grounding, and resonance grounding were widely introduced in distribution networks. This changed the operation mechanism and characteristic properties of single-phase earth fault significantly.

The existing sequence networks for single-phase earth fault are actually an analytical model under very special parameter conditions, which are only applicable if the neutral grounding impedance is small enough. However, this is not emphasized or explained explicitly in most textbooks and professional papers. Instead, a strange phenomenon sometimes occurs where the neutral resistance ( $R_n$ ) is defined in initial conditions but does not appear in the derived equation of fault current. This is confusing, as the neutral resistance is a component of the fault circuit but vanishes in the process of current calculation. Therefore, it is important to clarify and argue this issue clearly to form the basic theoretical position of the sequence networks, which will also be beneficial in guiding and carrying out practical work correctly.

**Introduction**

Assume that single-phase earth fault occurs somewhere in the feeder of phase A, the phase B and C still stay healthy. Accord-

ing to fig.1, it's obvious that the fault conditions can be written as under:

$$\begin{cases} \dot{I}_{bf} = \dot{I}_{cf} = 0 \\ \dot{U}_{af} = R_f \cdot \dot{I}_{af} \end{cases} \dots(1)$$

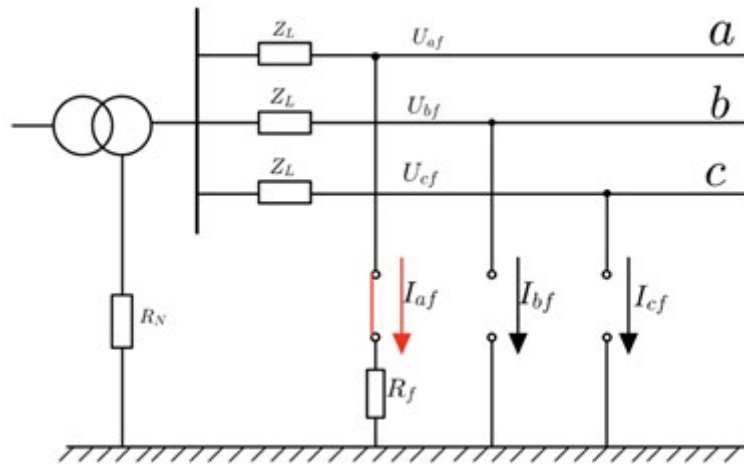

**Figure 1:** Single phase earth fault diagram

With equation (1), the phase-to-ground current can be transformed to three sequence current as below:

$$\begin{bmatrix} \dot{I}_{af1} \\ \dot{I}_{af2} \\ \dot{I}_{af0} \end{bmatrix} = \frac{1}{3} \begin{bmatrix} 1 & a & a^2 \\ 1 & a^2 & a \\ 1 & 1 & 1 \end{bmatrix} \begin{bmatrix} \dot{I}_{af} \\ \dot{I}_{bf} \\ \dot{I}_{cf} \end{bmatrix} = \frac{1}{3} \begin{bmatrix} 1 & a & a^2 \\ 1 & a^2 & a \\ 1 & 1 & 1 \end{bmatrix} \begin{bmatrix} \dot{I}_{af} \\ 0 \\ 0 \end{bmatrix} = \frac{\dot{I}_{af}}{3} \begin{bmatrix} 1 \\ 1 \\ 1 \end{bmatrix} \dots(2)$$

equation (2) shows that the positive, negative and zero sequence currents at fault are exactly same to one third of faulty phase current, i.e.

$$\dot{I}_{af1} = \dot{I}_{af2} = \dot{I}_{af0} = \frac{\dot{I}_{af}}{3} \dots(3)$$

And,

$$\dot{U}_{af} = \dot{U}_{af1} + \dot{U}_{af2} + \dot{U}_{af3} = 3R_f \cdot \dot{I}_{af1} \dots(4)$$

The symmetrical components of the voltage at fault may be written as:

$$\dot{U}_{af1} = \dot{U}_{af[0]} - Z_{L1} \cdot \dot{I}_{af1} \dots(5)$$

$$\dot{U}_{af2} = 0 - Z_{L2} \cdot \dot{I}_{af2} \dots(6)$$

$$\dot{U}_{af0} = 0 - Z_{L0} \cdot \dot{I}_{af0} \dots(7)$$

Where  $Z_{L1}, Z_{L2}, Z_{L0}$  refer to total sequence impedance of line and windings of transformers (if any).

By Summing up the both sides of the equation (5), (6), (7) and considering the equation (3)(4) together, the result goes as:

$$\dot{I}_{af1} = \dot{I}_{af2} = \dot{I}_{af0} = \frac{\dot{U}_{af[0]}}{3R_f + Z_{L1} + Z_{L2} + Z_{L0}} \quad \dots(8)$$

Where,  $U_{af[0]}$  is the voltage of phase A at fault point before fault.

And finally,

$$\dot{I}_{af} = \frac{3\dot{U}_{af[0]}}{3R_f + Z_{L1} + Z_{L2} + Z_{L0}} \quad \dots(9)$$

Thus, the sequence networks for SL earth fault can be drawn according to eq.(9) as below:

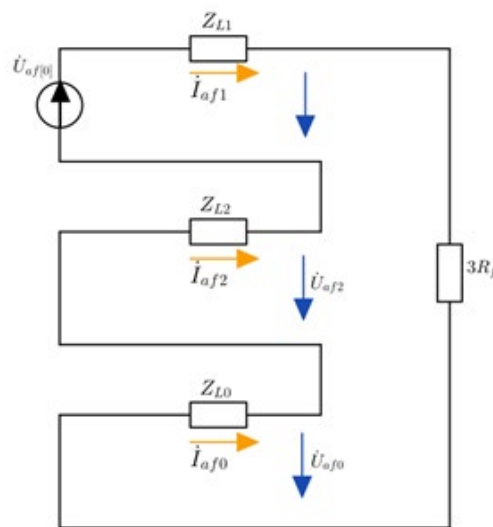

**Figure 2:** Sequence Networks in series for SL earth fault

However, the defined neutral resistance in fig.1 is not appeared in equation (9) and fig.2 which is definitely not reasonable, because neutral resistance  $R_n$  is included obviously in the fault circuit, to be precise, in the zero-sequence circuit.

For a delta connection of transformer, the neutral point has to be built through a Z type ground transformer that connecting to three-phase bus on top, and to earth via a resistance  $R_n$  below.

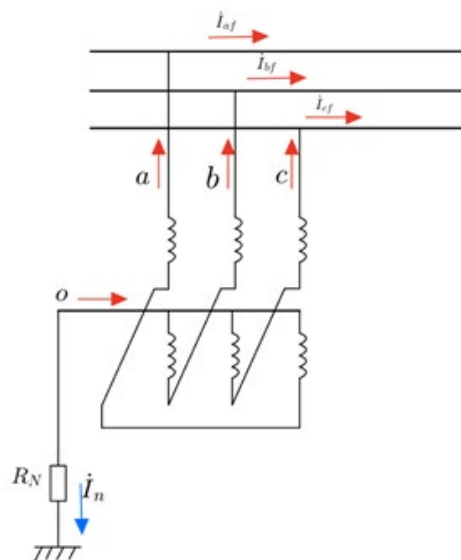

**Figure 3:** Neutral point induced by Z type grounding transformer

Now the neutral voltage that dropped on the  $R_n$  is possible to be calculated as:

$$\dot{U}_{en} = -(\dot{I}_{af} + \dot{I}_{bf} + \dot{I}_{cf}) \cdot R_N \quad \dots(10)$$

Due to the fault current each phase can be converted into symmetrical components as below:

$$\begin{cases} \dot{I}_{af} = \dot{I}_{af1} + \dot{I}_{af2} + \dot{I}_{af0} \\ \dot{I}_{bf} = a^2 \dot{I}_{af1} + a \dot{I}_{af2} + \dot{I}_{af0} \\ \dot{I}_{cf} = a \dot{I}_{af1} + a^2 \dot{I}_{af2} + \dot{I}_{af0} \end{cases} \quad \dots(11)$$

equation (10) can be solved as following:

$$\dot{U}_{en} = -(\dot{I}_{af1} + a^2 \dot{I}_{af1} + a \dot{I}_{af1}) \cdot R_N - (\dot{I}_{af2} + a \dot{I}_{af2} + a^2 \dot{I}_{af2}) \cdot R_N - (\dot{I}_{af0} + \dot{I}_{af0} + \dot{I}_{af0}) \cdot R_N$$

Obviously, the result is:

$$\dot{U}_{en} = -\dot{I}_{af0} \cdot 3R_N \quad \dots(12)$$

If we now review equation (7), we will find that it is incomplete and that the term for the neutral resistance is strangely missing. Only if the neutral resistance is Zero, the eq.(7) can be correct. Hence, the complete equation of zero-sequence voltage should be as:

### General Derivation with Capacitance Included in The Fault Circuit

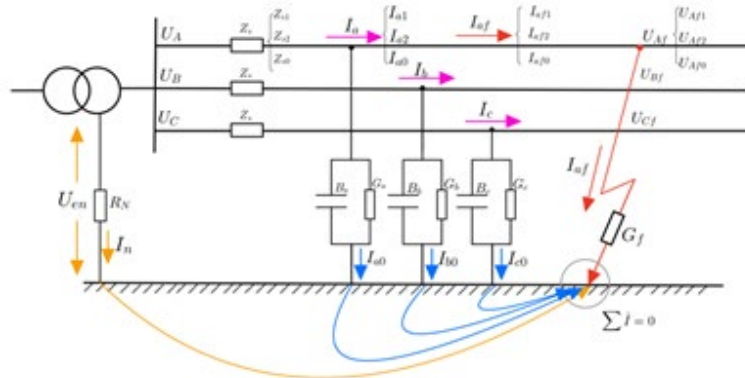

Figure 4: Complete earth fault circuit diagram in distribution networks

After we consider the line to ground impedance (mainly the capacitance), the equation for the fault point (node) can be given according to Kirchhoff's current law as:

$$\dot{U}_{en} \cdot G_N + U_{Af} \cdot Y_A + U_{Bf} \cdot Y_B + U_{Cf} \cdot Y_C + \dot{U}_{Af} \cdot G_f = 0 \quad \dots(15)$$

Where  $Y_A, Y_B, Y_C$  are the total admittance of each phase to ground, and assume that  $Y_A = Y_B = Y_C$ .  $G_N$  and  $G_f$  are conductance of  $R_N$  and  $R_f$

Symmetrical components of phase voltages can be written as:

$$\begin{cases} \dot{U}_{Af} = \dot{U}_{Af1} + \dot{U}_{Af2} + \dot{U}_{Af0} \\ \dot{U}_{Bf} = a^2 \dot{U}_{Af1} + a \dot{U}_{Af2} + \dot{U}_{Af0} \\ \dot{U}_{Cf} = a \dot{U}_{Af1} + a^2 \dot{U}_{Af2} + \dot{U}_{Af0} \end{cases} \quad \dots(16)$$

$$\dot{U}_{af0} = 0 - Z_{L0} \cdot \dot{I}_{af0} - \dot{I}_{af0} \cdot 3R_N \quad \dots(13)$$

Re-summing both sides of the equation (11) and (5)(6) to yield the result as:

$$\dot{I}_{af} = \frac{3\dot{U}_{af(0)}}{3R_f + 3R_N + Z_{L1} + Z_{L2} + Z_{L0}} \quad \dots(14)$$

When  $R_n=0$ , equation (14) returns to the case of equation (10).

But if we take  $R_n$  to infinity to simulate the ungrounded system with neutral opened, the equation (14) tends to zero, which obviously does not correspond to the actual situation when a SL earth fault occurs in ungrounded system.

According to Kirchhoff's Law, the fault current  $I_{af}$  value should equal to total capacitive current that flows from the line-to-ground capacitance and paralleled leakage resistance, rather than zero ampere that derived from equation (14) by taking the  $R_n$  to infinity and  $R_f$  to Zero as a bolted fault.

Therefore, only if the capacitance is considered in the circuit, we may derive a more general formula which is capable of widely applying in solid grounding system, low resistance grounding and of course the ungrounded system as desired.

Substituting equation (16) into equation (15) gives that:

$$\dot{U}_{m0} \cdot G_N + \dot{U}_{Af1} (Y_A + a^2 Y_B + a Y_C) + \dot{U}_{Af2} (Y_A + a Y_B + a^2 Y_C) + \dot{U}_{Af0} (Y_A + Y_B + Y_C) + \dot{U}_{Af1} \cdot G_f + \dot{U}_{Af2} \cdot G_f + \dot{U}_{Af0} \cdot G_f = 0 \quad (17)$$

If the positive and negative sequence related terms in eq. (17) are abstracted as current sources, it helps to make Figure 4 to be an equivalent circuit diagram that's simpler and easier to see. They're defined here below:

- *Controlled current source 1:*  $I_{S1} = U_{af1} * G_f$
- *Controlled current source 2:*  $I_{S2} = U_{af1} (Y_A + a^2 Y_B + a Y_C)$
- *Controlled current source 3:*  $I_{S3} = U_{af2} * G_f$
- *Controlled current source 4:*  $I_{S4} = U_{af2} (Y_A + a Y_B + a^2 Y_C)$

As learnt that positive and negative voltages at bus remain the same as the values at fault free, source IS2 and source IS2 can be ignored if assuming  $Y_A = Y_B = Y_C$ .

Thus, the complete equivalent circuit diagram can be drawn as shown in Figure 5.

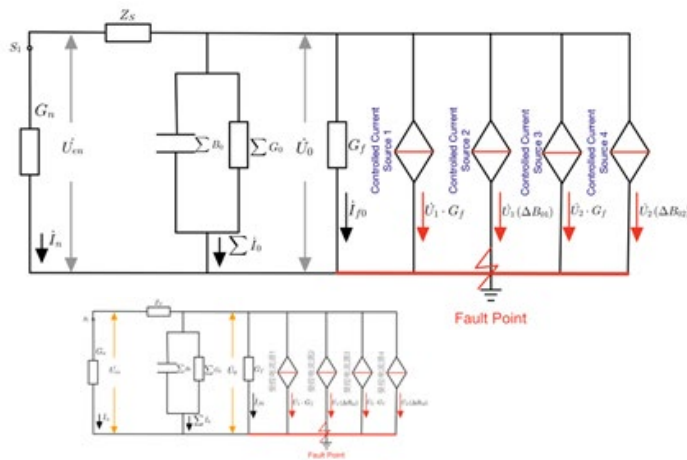

**Figure 5:** Equivalent circuit diagram to fig.4 with earth fault

The equations of sequence voltages at fault point is similar to equation (5)(6) (13), to be more general, the negative and zero sequence voltage before fault is not defaulted to zero, meanwhile balanced load current also defined and considered during the process of derivation on below.

Figure 6 shows the relations of sequence voltages at fault and at bus.

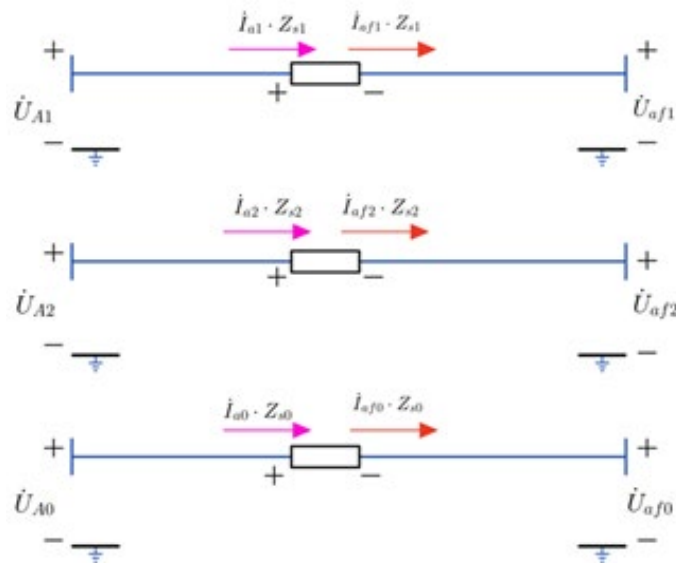

**Figure 6:** Sequence voltages relations at fault and at bus after fault

Given that positive and negative voltage at bus after fault remain unchanged, while only zero sequence voltage is drove to different position compared to one before fault due to the fault impedance  $R_f$  break the balance of phase to ground impedances.

Therefore, the sequence voltages at fault equal to:

$$\begin{cases} \dot{U}_{af1} = \dot{U}_{A1[0]} - \dot{I}_{a1}Z_{s1} - \dot{I}_{af1}Z_{s1} = \dot{U}_{af1[0]} - \dot{I}_{af1}Z_{s1} \\ \dot{U}_{af2} = \dot{U}_{A2[0]} - \dot{I}_{a2}Z_{s2} - \dot{I}_{af2}Z_{s2} = \dot{U}_{af2[0]} - \dot{I}_{af2}Z_{s2} \\ \dot{U}_{af0} = \dot{U}_{A0[0]} + \dot{U}_{en} - \dot{I}_{a0}Z_{s0} - \dot{I}_{af0}Z_{s0} = \dot{U}_{af0[0]} + \dot{U}_{en} - \dot{I}_{af0}Z_{s0} \end{cases} \dots(18)$$

Where,

$\dot{U}_{A1[0]}$ ,  $\dot{U}_{A2[0]}$ ,  $\dot{U}_{A0[0]}$  are sequence components of bus voltage of phase A before fault;

$\dot{I}_{a1}$ ,  $\dot{I}_{a2}$ ,  $\dot{I}_{a0}$  are sequence components of balanced load current of phase A before fault, the earth fault does not impact them that determined by loads.

$\dot{U}_{af1[0]}$ ,  $\dot{U}_{af2[0]}$ ,  $\dot{U}_{af0[0]}$  are sequence components of phase voltage at fault position before fault occurring.

$Z_{s1}$ ,  $Z_{s2}$ ,  $Z_{s0}$  are sequence impedance of lines and transformer windings etc.

Simplifying the equation (17) by substituting the equation (18) into to yield:

$$\dot{U}_{en} \cdot G_N + \dot{U}_{af0} \cdot Y_0 + \dot{U}_{af1[0]} \cdot G_f - \frac{\dot{I}_f}{3} \cdot G_f (Z_{s1} + Z_{s2} + Z_{s0}) + \dot{U}_{en} \cdot G_f = 0 \dots(19)$$

Where,

$$Y_0 = Y_A + Y_B + Y_C$$

And,

$$\dot{U}_{en} \cdot G_N + \dot{U}_{af0} \cdot Y_0 = -\dot{I}_f \quad (\text{Kirchhoff's law}) \dots(20)$$

$$\dot{U}_{en} \cdot G_f = \dot{I}_n \cdot R_N \cdot G_f = -(\dot{I}_f + \sum \dot{I}_0) R_N \cdot G_f = -\dot{I}_f \cdot R_N \cdot G_f - \dot{U}_{af0} \cdot Y_0 \cdot R_N \cdot G_f \dots(21)$$

According to fig.5, the zero-sequence voltage after fault can be solved as following:

$$\dot{U}_{af0} = -\dot{U}_{af[0]} \cdot \frac{(Z_{s0} + R_N) \cdot Z_{C0}}{(Z_{s0} + R_N) \cdot Z_{C0} + R_f (Z_{s0} + R_N + Z_{C0})} \dots (22)$$

Where,  $Z_{C0}=1/Y_0$ ,

By substituting equation (23) into equation (21), it gives:

$$\dot{U}_{en} \cdot G_f = -\dot{I}_f \cdot R_N \cdot G_f + \dot{U}_{af[0]} \cdot \frac{(Z_{s0} + R_N) \cdot R_N}{(Z_{s0} + R_N) \cdot Z_{C0} + R_f (Z_{s0} + R_N + Z_{C0})} \cdot G_f \dots(23)$$

Then, substituting equation (23) and equation (20) into equation (19), we can obtain the result as:

$$\dot{I}_f = \frac{3\dot{U}_{af[0]}}{3R_f + 3R_N + Z_{s1} + Z_{s2} + Z_{s0}} \cdot [1 + M] \dots(24)$$

Where,

$$M = \frac{(Z_{s0} + R_N) \cdot R_N}{(Z_{s0} + R_N) \cdot Z_{C0} + R_f (Z_{s0} + R_N + Z_{C0})} \dots(25)$$

$U_{en}$  formula can be derived by taking equation (25) into equation (23) as following:

$$\dot{U}_{en} = -\dot{U}_{Af[0]} \cdot \frac{3R_N - M \cdot (Z_{s1} + Z_{s2} + Z_{s0} + 3R_f)}{3R_f + 3R_N + Z_{s1} + Z_{s2} + Z_{s0}} \quad \dots(26)$$

In the meantime, equation (22) for zero sequence voltage at fault can be simplified as:

$$\dot{U}_{Af0} = -\dot{U}_{Af[0]} \cdot \frac{Z_{e0}}{R_N} \cdot M \quad \dots(27)$$

Compared with eq. (14) of sequence networks, eq. (24) further considers the effect of the capacitance to ground on the current at the fault point. To discriminate the two conclusions, it's can be assumed that an earth fault occurs in a distribution grid with capacitive current 150 amperes and with neutral resistance 10 ohms and 1000 ohms to simulate the low-resistance grounding and high-resistance grounding respectively, when the fault impedance  $R_f$  increases from zero to infinity, the difference between two conclusions of eq. (24) and (14) can be visualized from the curves of fault current.

When  $R_N=10$  Ohms, the fault current curves are plotted below. Yellow curve corresponding to the equation (24) and blue one to equation (14).

Other main parameter settings:

- Rated voltage: 10kV/0° (with +5% margin)
- Load current of Phase A: 100A/-18°
- Positive sequence impedance:  $Z_{S1}=Z_{S2}=(0.45+j0.35)$  /km
- Zero sequence impedance:  $Z_{S0}=(0.45+j1.05)$  /km
- Distance btw fault and bus: 5km

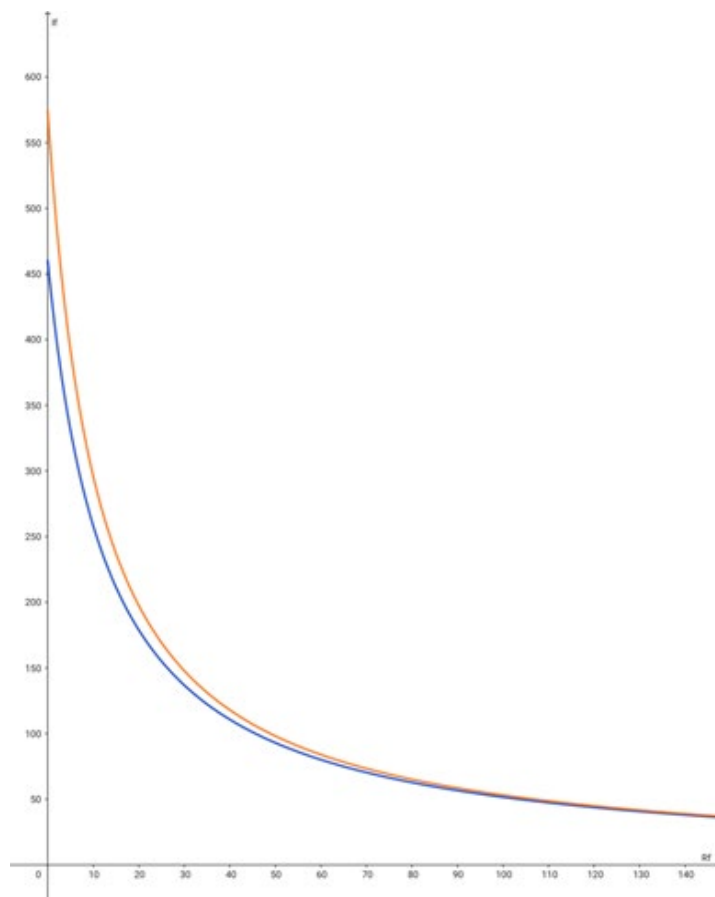
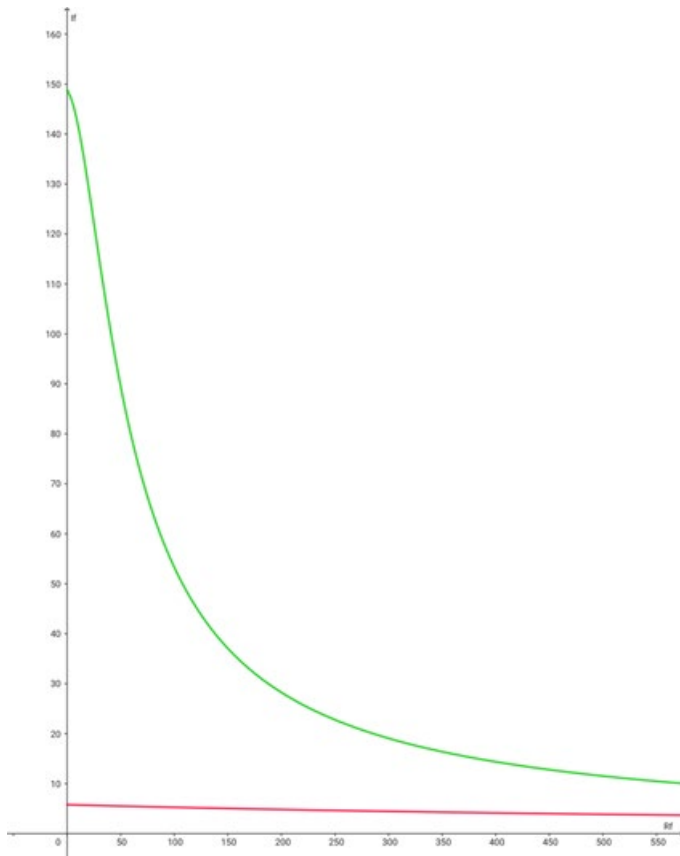

**Figure 7:** Fault current comparison with  $R_N=10$  Ohms

In Fig.7, it can be seen that the largest difference is shown at  $R_f=0$  Ohm, i.e. bolted earth fault, and results of equation (24) and equation (14) are 574A and 460A respectively, as the fault impedance going larger up to 130 Ohms, there is very minor difference between them, which means that the error of sequence networks can be neglected when fault impedance is not too small, let's say  $R_f > 50$  Ohms.

However, in the case of neutral resistance  $R_N=10$  Ohms, approximately the results of two equations can be considered similar each other, because it's nothing different for overcurrent protection to see that one current is 50A or 100A larger than the other one, the protection can be triggered as long as the current just is greater than the threshold value.

When  $R_N=1000$  Ohms, the fault current curves are plotted below. Green curve corresponding to the equation (24) and red one to equation (14).



**Figure 8:** Fault current comparison with  $R_N=1000$  Ohms

In this case, the sequence networks modelling does not work anymore since the fault current is going out of practice while fault impedance changes from 0 to infinity. Obviously, for a bolted earth fault, the fault current should equal to the sum-up of neutral current and capacitive current, as mentioned initially, 150A capacitive current is set through the whole simulations, therefore, the fault current should be at the level of capacitive current when  $R_f=0$  Ohms, not possible to keep less than 6A whatever the fault impedance is as shown in Fig.8.

Fortunately, our new modeling with equation (24) gives more accurate result which can be seen in Fig.8, the maximum fault current 148.8A is very close to the capacitive current 150A when  $R_f=0$  Ohms, the little tiny difference comes from the impact of small neutral current.

Imagine that when we changed the neutral resistance  $R_N$  from zero to infinity under the same grid conditions, the minimum value of calculating difference between equation (24) and equation (14) is zero only when neutral point is solidly grounded, i.e.  $R_N=0$ , and the maximum is equivalent to the grid capacitive current when it's an ungrounded system, i.e.  $R_N=\infty$ .

### Validation Check from General to Specific

In this paper, we propose a new model and derive the general equations, whether the conclusions are fully consistent with the grid operation, surely it should be strictly verified in simulation tests or real practical applications.

A simple way to estimate the concluded equations is to set special parameters such as letting  $R_f=0$  or  $Z_{c0}=\infty$  in order to simplify the general equations to special ones which can be easily observed and analyzed in a specific perspective.

### Examples

1) Let  $R_N=0$  (**solid grounding**), the general equations become as follows.

a- Fault current:

$$I_f = \frac{3\dot{U}_{Af(0)}}{3R_f + Z_{s1} + Z_{s2} + Z_{s0}}$$

b- Neutral voltage:

$$\dot{U}_{cn} = 0$$

c- Zero-sequence voltage at fault:

$$\dot{U}_{A(0)} = -\dot{U}_{Af(0)} \cdot \frac{1}{1 + R_f \frac{Z_{s0} + Z_{s0}}{Z_{s0} Z_{c0}}}$$

Further, if we assume that  $R_f=0$ , the fault current is only determined by sequence impedance of lines, the neutral voltage stays at zero all the time, and zero sequence voltage at fault now is exactly opposite to the voltage of phase A before fault.

2) Let  $R_N=\infty$  (**ungrounded**), special results as following:

a- Fault current:

$$I_f = \frac{\dot{U}_{Af(0)}}{R_f + Z_{c0}}$$

b- Neutral voltage:

$$\dot{U}_{cn} = -\dot{U}_{Af(0)} \cdot \frac{3Z_{c0} - (Z_{s1} + Z_{s2} + Z_{s0})}{3Z_{c0} + 3R_f}$$

c- Zero sequence voltage at fault:

$$\dot{U}_{A(0)} = -\dot{U}_{Af(0)} \cdot \frac{Z_{c0}}{Z_{c0} + R_f}$$



The capacitance plays quite a key role with fault in ungrounded system, just assuming that  $R_f=0$ , the fault current is exactly same as the grid capacitive current, but angle is opposite. The neutral voltage is mainly determined by capacitance as well when fault impedance is close to zero, the sum-up of sequence impedances ( $Z_{s1} + Z_{s2} + Z_{s0}$ ) normally is far less than  $Z_{C0}$ , therefore, the line impedance is reasonably possible to be neglected in ungrounded system, in others words, neutral voltage can be taken as the same as zero-sequence voltage at fault, by this means, the impact to calculations is minor as per experiences.

3) Let  $Z_{s1}/Z_{s2}/Z_{s0} \rightarrow 0$  (**Fault at bus**), special results as following:

a- Fault current:

$$I_f = \frac{\dot{U}_{Af[0]}}{R_f + R_N} \cdot \left[ 1 + \frac{R_N}{R_N \cdot Z_{C0} + R_f(R_N + Z_{C0})} \right]$$

b- Neutral voltage:

$$\dot{U}_{en} = -\dot{U}_{Af[0]} \cdot \frac{1}{1 + R_f \frac{Z_{C0} + R_N}{Z_{C0} R_N}}$$

c- Zero sequence voltage at fault:

$$\dot{U}_{A[0]} = -\dot{U}_{Af[0]} \cdot \frac{1}{1 + R_f \frac{Z_{C0} + R_N}{Z_{C0} R_N}}$$

Earth fault at bus could produce much larger fault current than fault occurring anywhere on feeders which can be easily observed from the first equation above by comparing with the equation (24) mathematically.

4) Let  $Z_{C0} \rightarrow \infty$  (**ignorance of capacitive current**), special results as following:

a- Fault current:

$$I_f = \frac{3\dot{U}_{Af[0]}}{3R_f + 3R_N + Z_{s1} + Z_{s2} + Z_{s0}}$$

b- Neutral voltage:

$$\dot{U}_{en} = -\dot{U}_{Af[0]} \cdot \frac{3R_N}{3R_f + 3R_N + Z_{s1} + Z_{s2} + Z_{s0}}$$

c- Zero sequence voltage at fault:

$$\dot{U}_{A[0]} = -\dot{U}_{Af[0]} \cdot \frac{Z_{s0} + R_N}{Z_{s0} + R_N + R_f}$$

The above equations at this case can be also derived by the traditional sequence networks in the conditions of neglecting capacitive current that could result in considerable errors when fault impedance is less than 50 Ohms as we just analyzed in Fig. 8.

5) Let  $R_f \rightarrow 0$  (**bolded fault**), special results as following:

a- Fault current:

$$I_f = \frac{3\dot{U}_{Af[0]}}{3R_N + Z_{s1} + Z_{s2} + Z_{s0}} \cdot \left( 1 + \frac{R_N}{Z_{C0}} \right)$$

b- Neutral voltage:

$$\dot{U}_{en} = -\dot{U}_{Af[0]} \cdot \left[ 1 - \frac{R_N(Z_{s1} + Z_{s2} + Z_{s0})}{Z_{C0}(3R_N + Z_{s1} + Z_{s2} + Z_{s0})} \right]$$

c- Zero sequence voltage at fault:

$$\dot{U}_{en} = -\dot{U}_{Af[0]}$$

6) Let  $R_f \rightarrow \infty$  (**Normal operation**), special results as following:

a- Fault current:

$$I_f = 0$$

b- Neutral voltage:

$$\dot{U}_{en} = 0$$

c- Zero sequence voltage at fault:

$$\dot{U}_{A[0]} = 0$$

## Conclusions

This paper demonstrates the drawbacks of the conventional sequence networks model when applied to systems with high neutral grounding resistance. Since the effect of phase-to-ground capacitance increases with neutral resistance getting larger, the estimation approach of ignoring capacitive current in low resistance grounding systems leads to considerable calculation errors when applied to high resistance grounding systems, which calls for a more generalized set of derivative formulas to meet the practical needs for the increasing grid capacitance effects. With the proposed new model, the successful derivations and primary validation of the generalized formulas for fault current, neutral voltage, and zero-sequence voltage at fault allow for more accurate and effective analysis of single-phase earth fault in power systems.

When discussing electrical system protection, the more powerful phase-to-phase short circuit faults draw a large amount of attention. However, in practice, earth faults actually present a far more common, and potentially more dangerous occurrence for personnel and devices, since the earth fault could go undetected with very minor fault characteristics when fault impedance is relatively high. In order to sensitively detect such dangerous faults, the zero-sequence impedance has to be more capable of dividing voltage with fault impedance, which requires the neutral resistance/impedance to be set to a relatively higher value. By far, the best solution for neutral grounding should be a resonant system with a fully tuned Petersen coil and balance device for symmetrizing three-phase to ground capacitance [1-8].

---

On the basis of the new modelling and derivation method in this paper, it is easy to obtain fault analysis results for resonant grounding systems, i.e. fault current, neutral voltage, and zero-sequence voltage at fault, etc. The author would prefer to leave it to peers and engineers to derive it themselves for a better understanding of the significance of earth fault protection.

### References

1. Yu, Yongyuan Yang, Yee-Wen Yang, Power System Analysis, 2nd Edition. China Electric Power Press.
2. Blackburn, J. L., & Domin, T. J. (2006). Protective relaying: principles and applications. CRC press.
3. Anderson, P. M. (1973). Analysis of faulted power systems". Iowa State University Press.
4. E.O.Schweitzer, III and Stanley E. Zocholl, "Introduction to Symmetrical Components," proceedings of the 58th Annual Georgia Tech Protective Relaying Conference, Atlanta, GA, April 2004.
5. Li Guangqi, Power Fault Transient Analysis, 1st Edition. Water and Electric Power Publishing House.
6. Electricity Training Association. (1995). Power System Protection Volume 1: Principles and Components.
7. Tziouvaras, D. A., Roberts, J. B., & Benmouyal, G. (2001). New multi-ended fault location design for two-or three-terminal lines.
8. Li Runxian, Practical Techniques for Medium-Voltage Power Grid Grounding Systems, 1<sup>st</sup> Edition. China Electric Power Publishing House.

**Copyright:** ©2023 Yubo Wang. This is an open-access article distributed under the terms of the Creative Commons Attribution License, which permits unrestricted use, distribution, and reproduction in any medium, provided the original author and source are credited.